

Sistema AM-B(rt)



sistema de batente de alumínio / madeira com rutura térmica

aluminium / wood opening system with thermal break

système d'ouvrant de aluminium / bois à rupture de pont thermique



SISTEMAS
EURO 2000[®]
PERFIS DE ALUMÍNIO E VIDROS PARA ARQUITECTURA



Características do Sistema

System features

Caractéristiques du système

Porque tudo evolui no sentido de melhorar, também o sistema de Alumínio/Madeira se recriou surgindo agora com a vertente de rutura térmica, dando assim resposta às atuais exigências de conforto térmico e acústico mas mantendo a sua característica primeira: conferir às edificações o vínculo entre a tradição e a modernidade.

Because everything evolves to improve, so the system Aluminum / Wood has recreated itself, emerging now with the thermal break strand, thus responding to the current demands of thermal and acoustic comfort but maintaining its characteristic first: give the building the bond between tradition and modernity.

Parce que tout évolue à améliorer, aussi le système aluminium / bois a été recréé en train d'émerger avec rupture de pont thermique, répondant ainsi aux exigences actuelles de confort thermique et acoustique tout mais en conservant sa première caractéristique: confèrent au bâtiment le lien entre tradition et modernité.

Apresentação:	Retã Oval	
Presentation	Straight Oval	
Présentation	Droite Ovale	
Dimensões:	Aro Fixo:	80mm
Dimensions	Fixed frame:	80mm
Dimension	Cadre fixe:	80mm
	Aro Móvel:	104mm
	Mobile frame:	104mm
	Cadre mobile:	104mm
Bites:	Retos ou Ovais	
Glazing beads	Straight or Oval	
Parcloses	Droite ou Ovale	
Enchimento:	58mm (Máximo)	
Filling	58mm (Maximum)	
Remplissage	58mm (Maximale)	
Cortes:	45°	
Cuts	45°	
Coupes	45°	
Vedação:	Vedantes em EPDM	
Insulation	EPDM sealants	
Étanchéité	Joint en EPDM	
Canal:	Canal de 16mm	
Channel	16mm channel	
Chenal	Chenal de 16mm	
Peso máximo:	Janela batente (int./ext. 1 2 folhas) - 100 Kg/folha leaf vantail	
Maximum weight	Casement (in/out 1 2 leaves) Fenêtre à la française (int./ext. 1 2 vantaux)	
Poids maximale	Porta batente (int./ext. 1 2 folhas) - 150 Kg/folha leaf vantail	
	French door (in/out 1 2 leaves) Porte (int./ext. 1 2 vantaux)	
	Oscilo-batente (1 2 folhas) - 100 Kg/folha leaf vantail	
	Tilt and turn (1 2 leaves) Oscillo-Battant (1 2 vantaux)	
	Basculante - 100 Kg/folha leaf vantail	
	Hopper À soufflet	
Acabamentos:	Exterior:	Lacados Anodizados
Finishes	Outside:	Powder coated Anodizing
Finitions	Extérieur:	Laqué Anodisé
	Interior:	Madeira maciça (Carvalho, Mogno, Cerejeira, Nogueira, Faia, outros sob consulta)
	Inside:	Hard wood (Oak, Mahogany, Cherry, Walnut, Beech, others on request)
	Intérieur:	Bois (Chêne, Acajou, Cerisier, Noyer, Hêtre, autres sur demande)



Licença nº. 1406 - Metalferr
Licença nº. 1411 - Alfa Sul



Licença nº. 809



Batente int. | ext. 1 | 2 folhas
casement in | out 1 | 2 leaves
française int. | ext. 1 | 2 vantaux

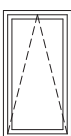

Basculante
hopper
à soufflet



Porta | Door | Porte
Batente int. | ext. 1 folha
french door in | out 1 leaf
française int. | ext. 1 vantail



Oscilo-batente 1 | 2 folhas
tilt and turn 1 | 2 leaves
oscillo-battant 1 | 2 vantaux

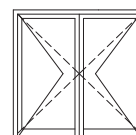

Porta | Door | Porte
Batente int. | ext. 2 folhas
french door in | out 2 leaves
française int. | ext. 2 vantaux

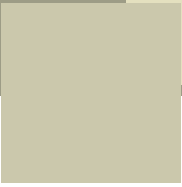



5

Listagem de perfis

Profile list

Liste des profiles

15

Acessórios

Accessories

Accessoires

23

Pormenores de montagem

Assembly details

Détails de montage

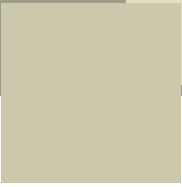

Listagem de perfis

Profile list

Liste des profiles

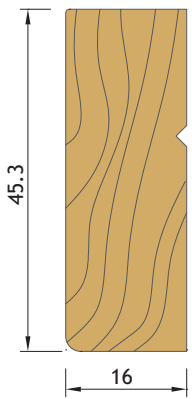

PM 67

Madeira | Wood | Bois

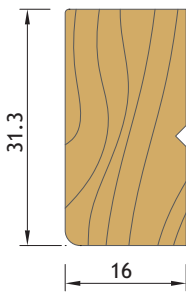

PM 77

Madeira | Wood | Bois

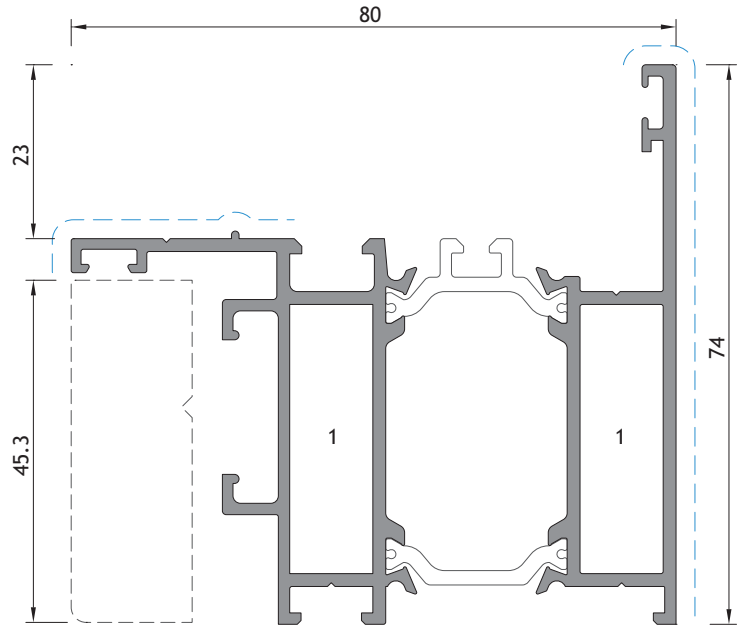

AM 67

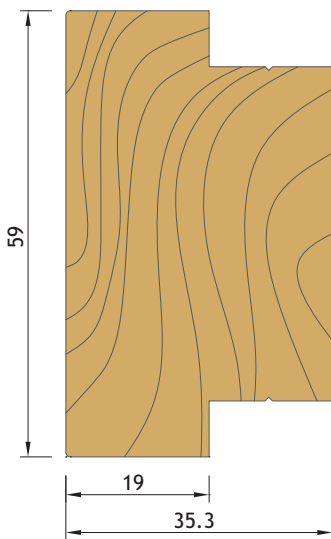

PM 64

Madeira | Wood | Bois

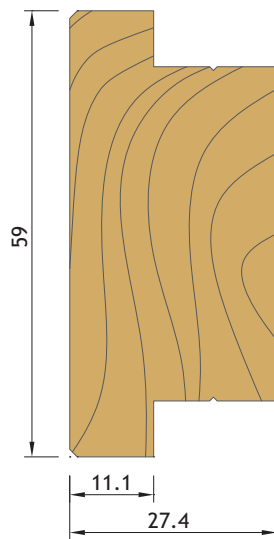

PM 14

Madeira | Wood | Bois

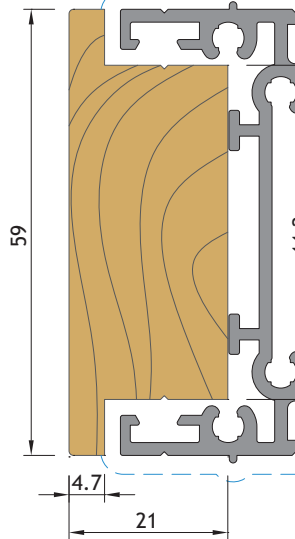

PM 36

Madeira | Wood | Bois

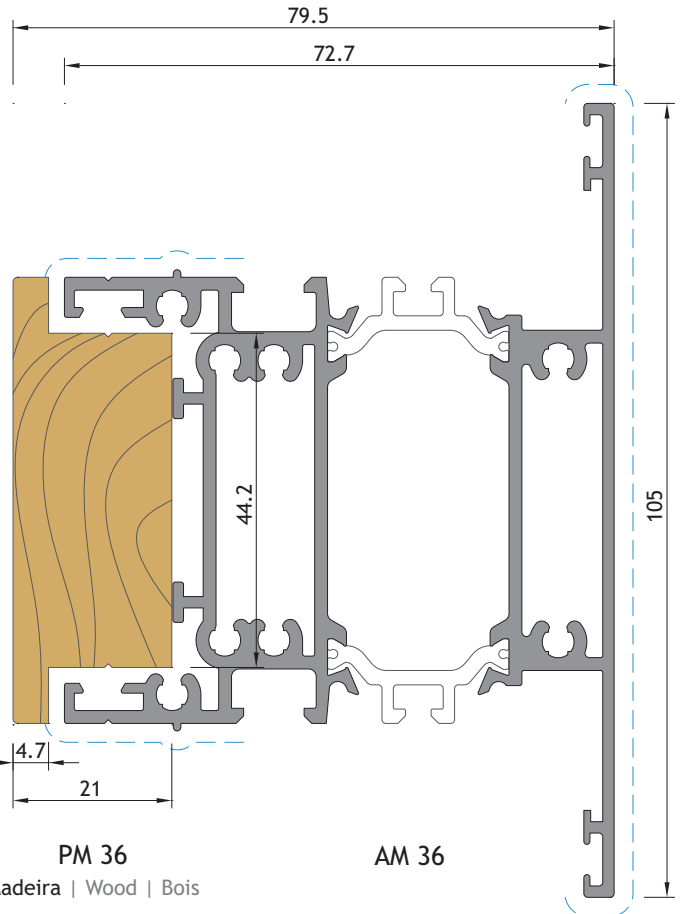

AM 36

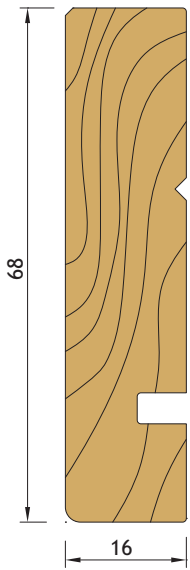

PM 88

Madeira | Wood | Bois

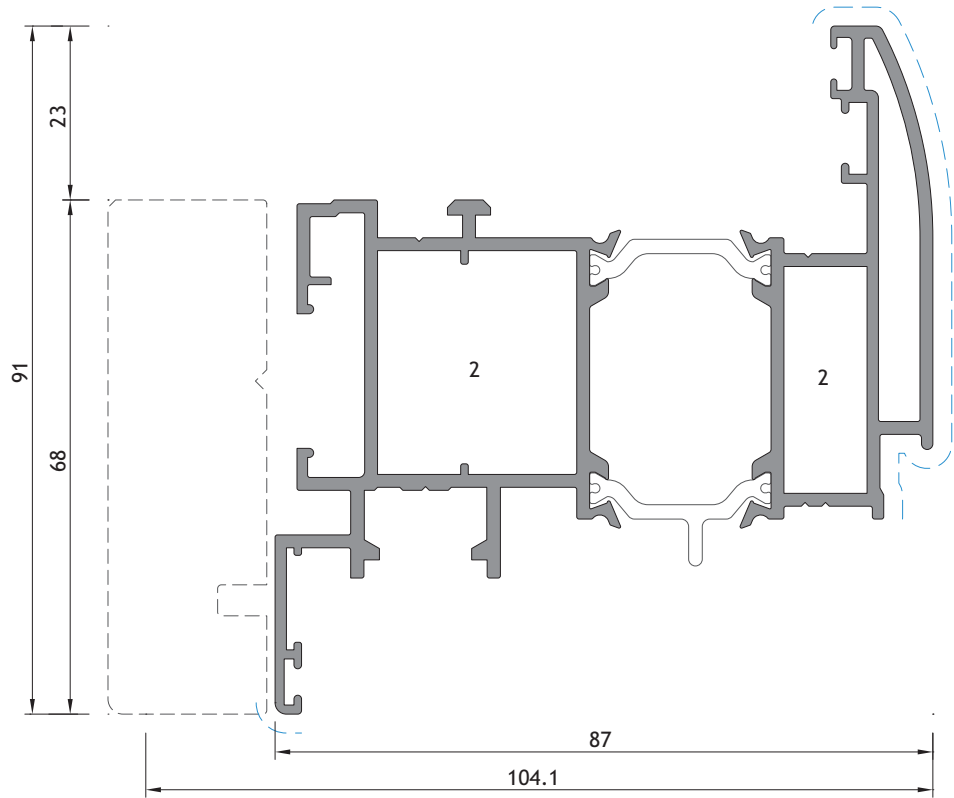

AM 88

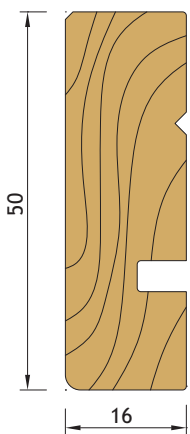

PM 65

Madeira | Wood | Bois

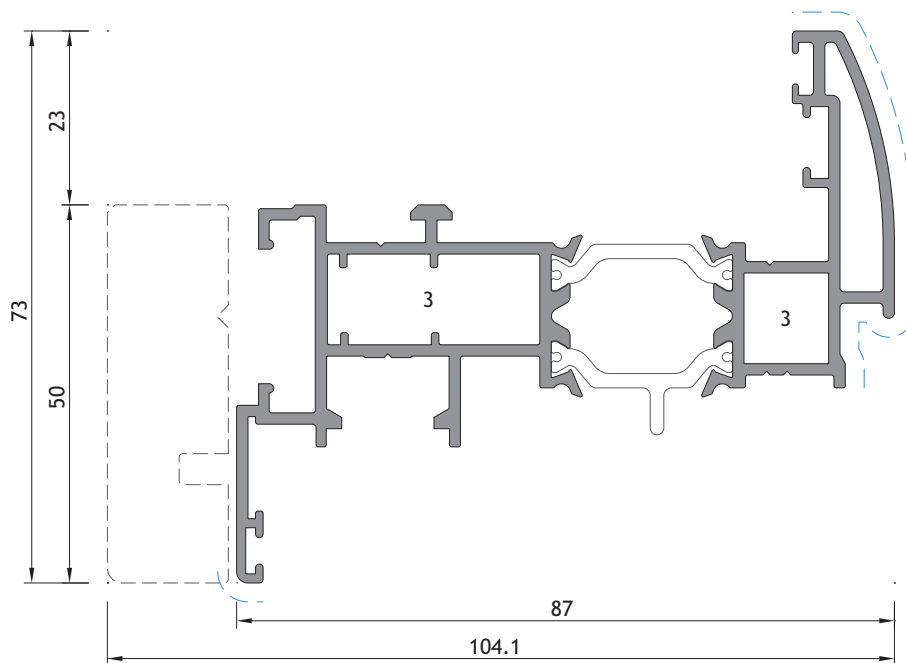

AM 65

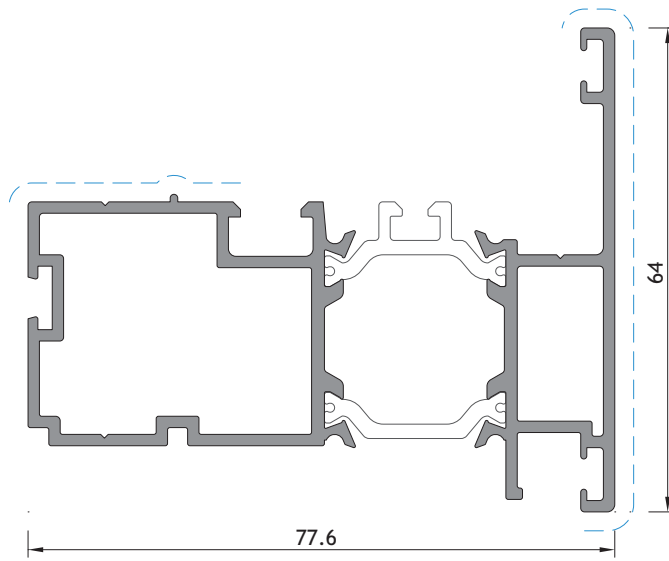

AM-16

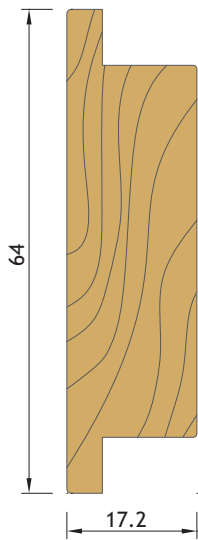

PM-24
 Madeira | Wood | Bois

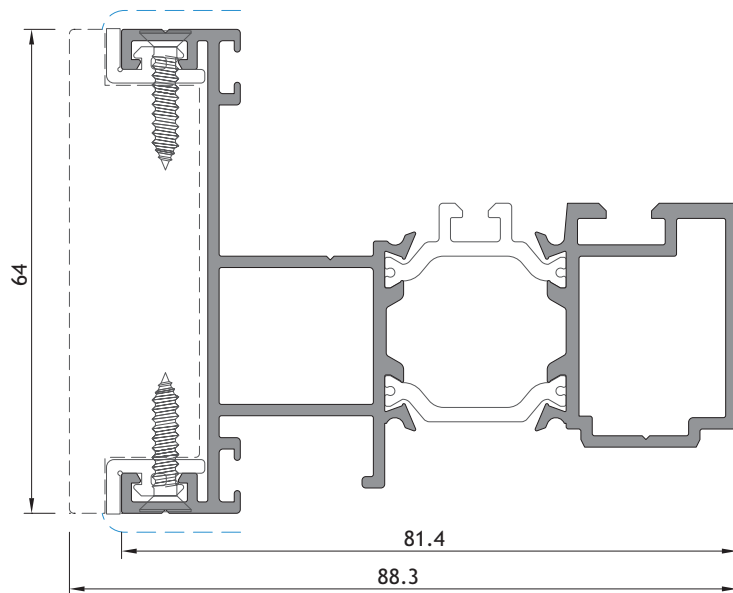

AM-24

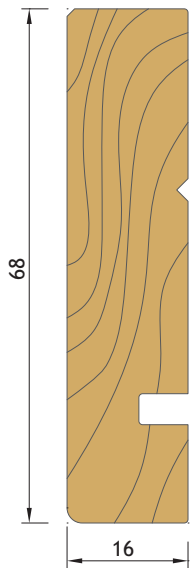

PM-88
 Madeira | Wood | Bois

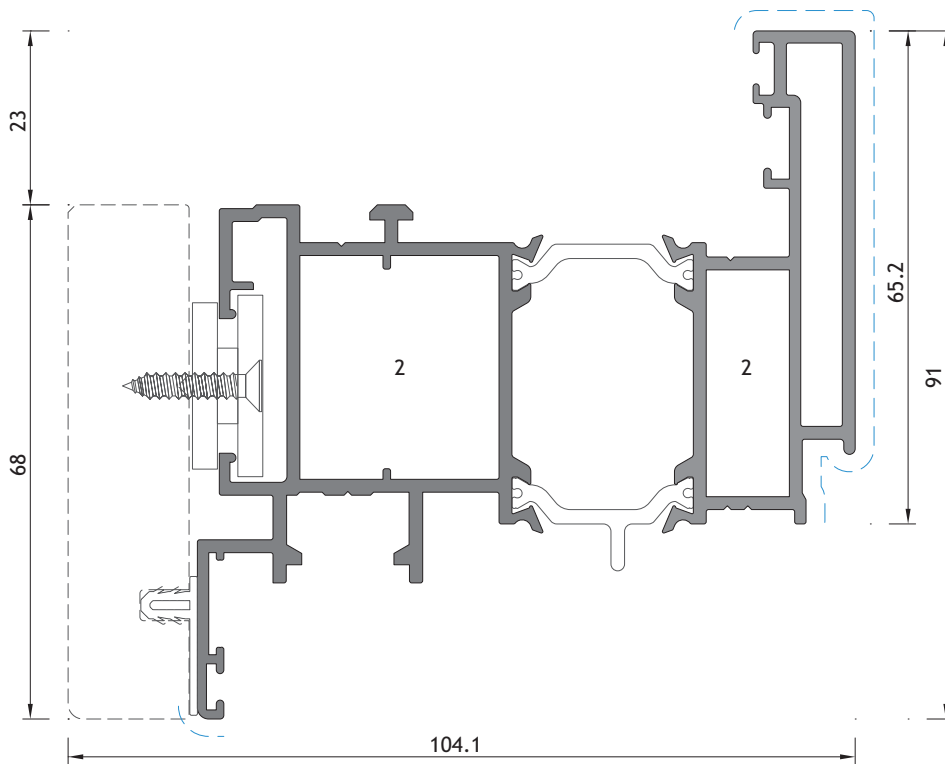

AM-11
 Disponibilidade sujeita a consulta
 Availability under consulting
 Disponibilité sur demande

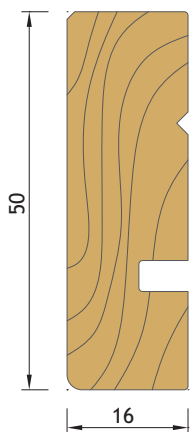

PM-65
 Madeira | Wood | Bois

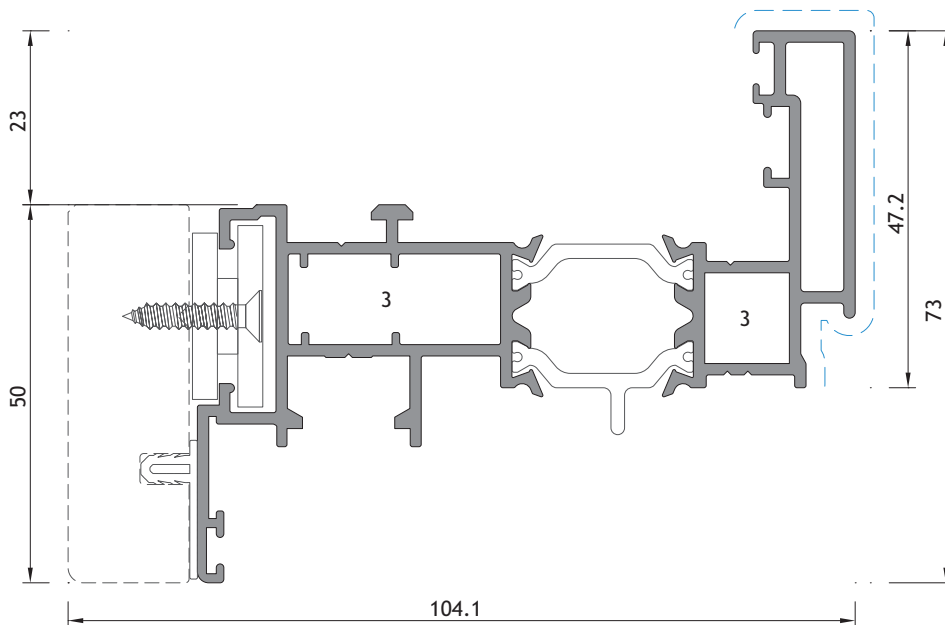

AM-02
 Disponibilidade sujeita a consulta
 Availability under consulting
 Disponibilité sur demande

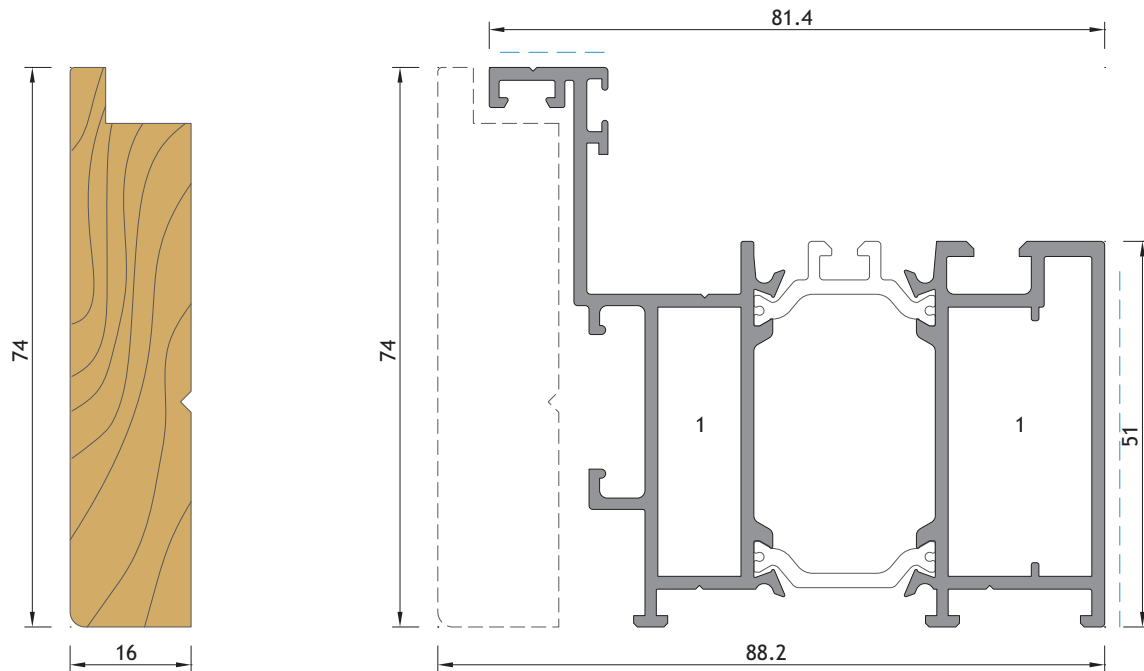

PM-68
 Madeira | Wood | Bois

AM-68
 Disponibilidade sujeita a consulta
 Availability under consulting
 Disponibilité sur demande

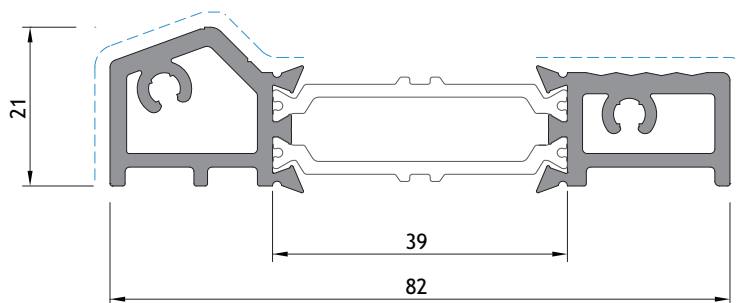

AM-50

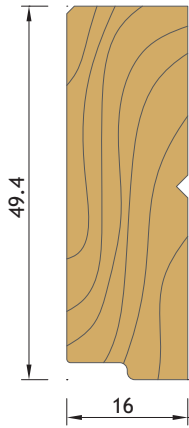

PM-69
 Madeira | Wood | Bois

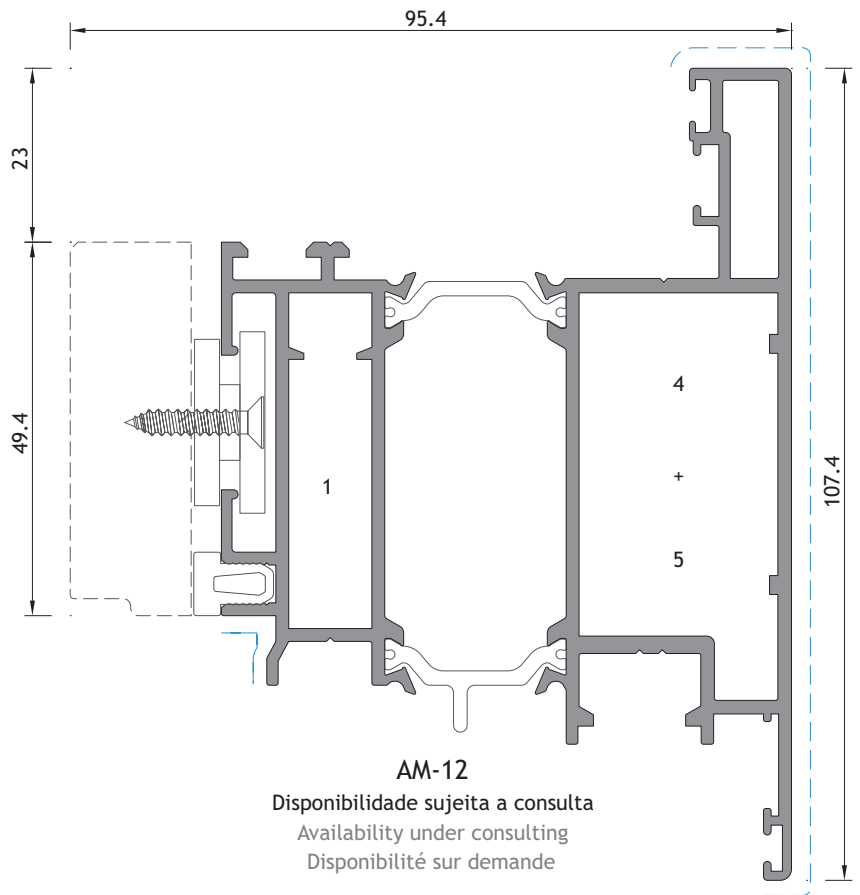

AM-12
 Disponibilidade sujeita a consulta
 Availability under consulting
 Disponibilité sur demande

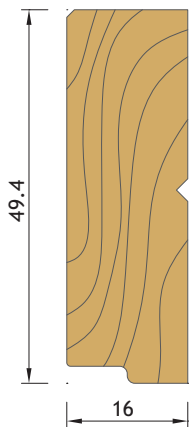

PM-69
 Madeira | Wood | Bois

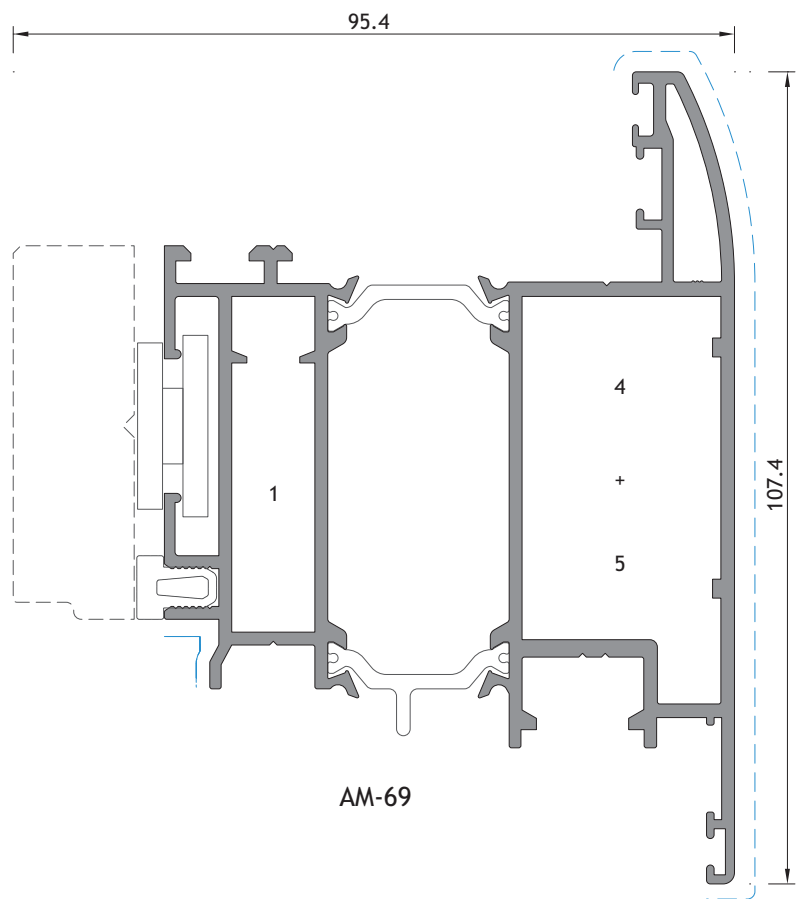

AM-69

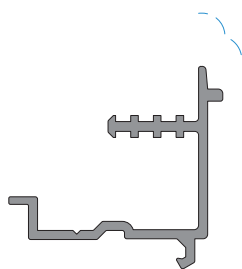

AM-90

LINHA OVAL | OVAL MODEL | LIGNE OVALE

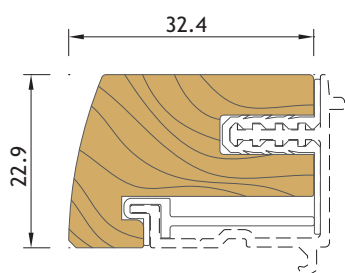

PM-94

Madeira | Wood | Bois

LINHA RETA | STRAIGHT MODEL | LIGNE DROITE

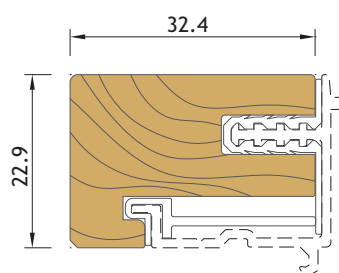

PM-95

Madeira | Wood | Bois

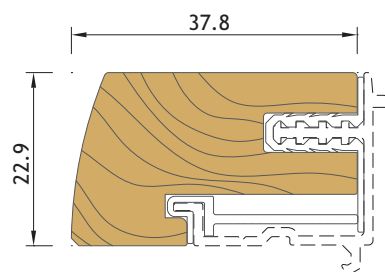

PM-92

Madeira | Wood | Bois

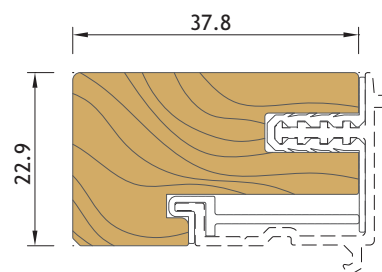

PM-93

Madeira | Wood | Bois

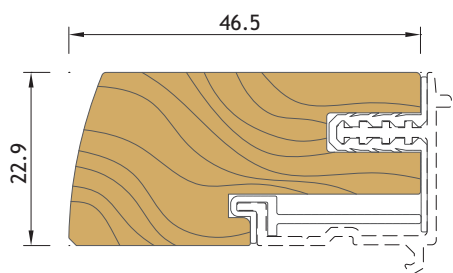

PM-90

Madeira | Wood | Bois

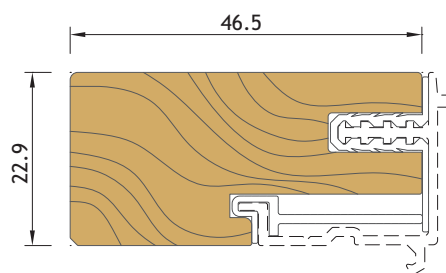

PM-91

Madeira | Wood | Bois

TABELA DE BITES | GLAZING BEADS | PARCLOSES

LINHA OVAL | OVAL MODEL | LIGNE OVALE

LINHA RETA | STRAIGHT MODEL | LIGNE DROITE

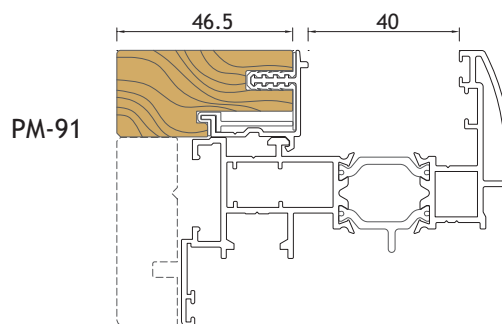
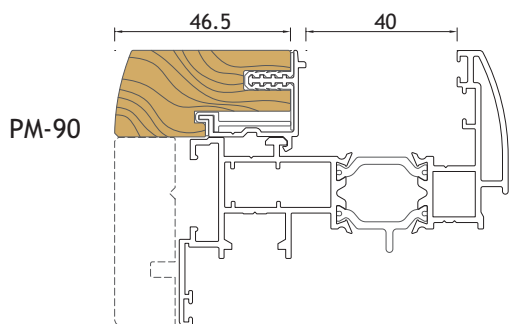
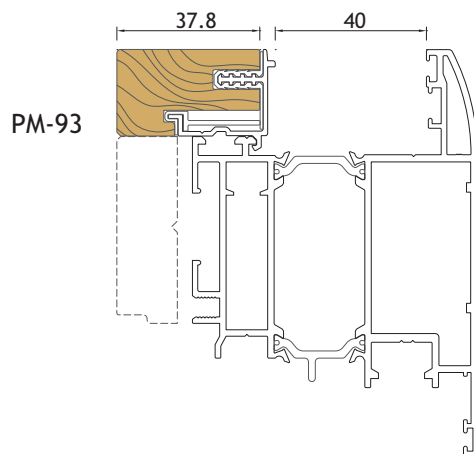
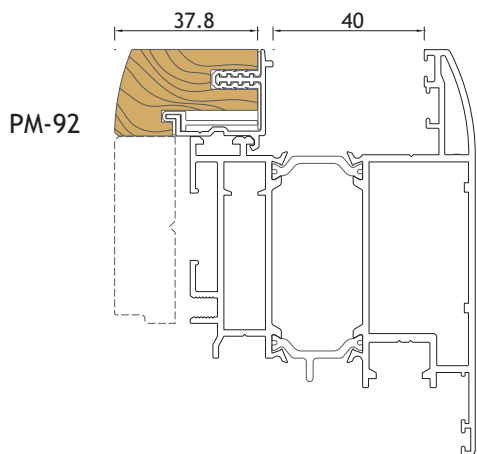
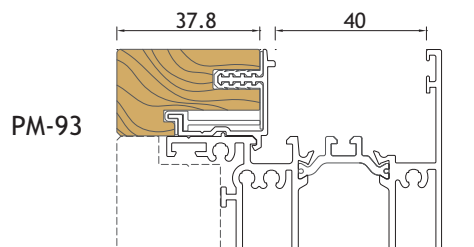
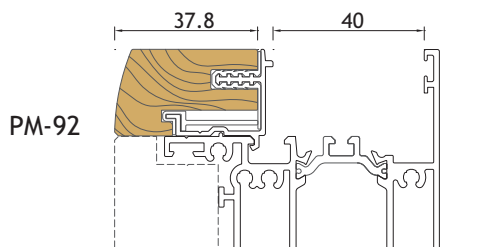
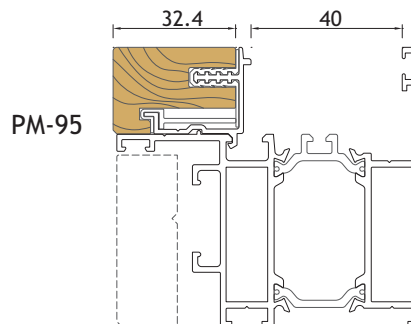
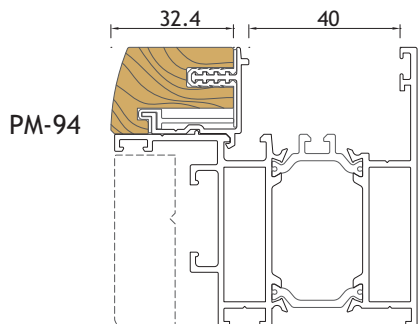



Acessórios

Accessories

Accessoires



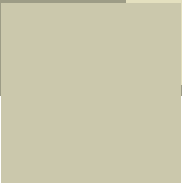



2001
(Material: EPDM)
(Caixa: 8 rolosx50m)
(Aplicar em projectantes)



2051
(Material com 2 durezas)
Zona de batente: E.P.D.M. esponjoso)
(Base: E.P.D.M. de 70° SHORE)
(Rolo: 300m (150m+150m))

208274
208008

JUNTA DE ESTANQUIDADE 2001
JUNTA DE ESTANQUIDADE 2051



A aplicação da junta 2112 é facultativa

208399

JUNTA DE REMATE PAREDE VD 2400 PRT



2003
Material: EPDM
Rolo: 100m



2055
Material: EPDM
Rolo: 200m

208350
208289

JUNTA DE VEDAÇÃO EXTERIOR 2003
JUNTA DE BATENTE 2055



Rolo: 200m

208435

JUNTA VD 2415 PRT

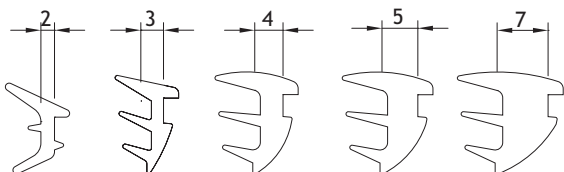

2042

2073

2034

2035

2037

Material: EPDM
Rolo: 200m

208191 JUNTA DE CUNHA 2042
208195 JUNTA DE CUNHA 2034

208196 JUNTA DE CUNHA 2035
208904 JUNTA DE CUNHA 2037
208199 JUNTA DE CUNHA 2073

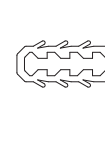

Rolo: 200m

208413

JUNTA VD 2411 PRT



2112

Material: EPDM
Rolo: 200m

208278

JUNTA DE ESTANQUIDADE 2112

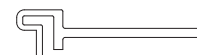

Rolo: 200m

208411

JUNTA VD 2410 PRT

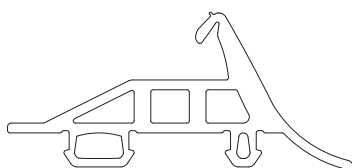

Para vãos de abertura para interior.
Material: EPDM
Barra dupla: 6.5mx2

208400

JUNTA DE DE VEDAÇÃO CENTRAL VD 2405 PRT

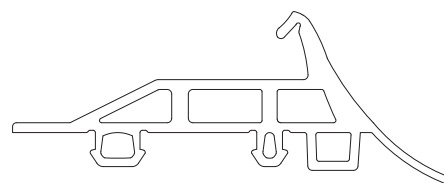

Para vãos de abertura para exterior.
Material: EPDM

000000

JUNTA DE DE VEDAÇÃO CENTRAL VD 2467 PRT



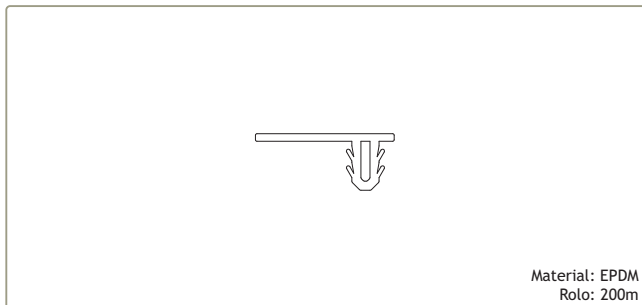

Material: EPDM
Rolo: 200m

208437

JUNTA VD 2420 PRT

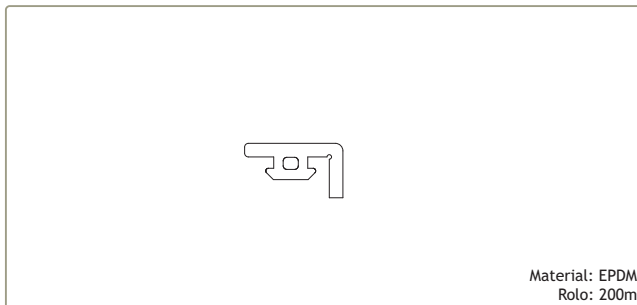

Material: EPDM
Rolo: 200m

208194

JUNTA DISTANCIADORA VR 2202

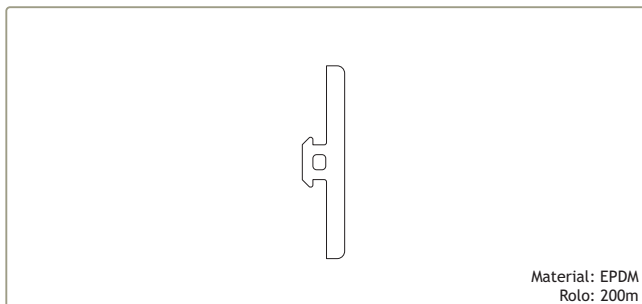

Material: EPDM
Rolo: 200m

208124

JUNTA CENTRAL PARA TRAVESSA VR 2203

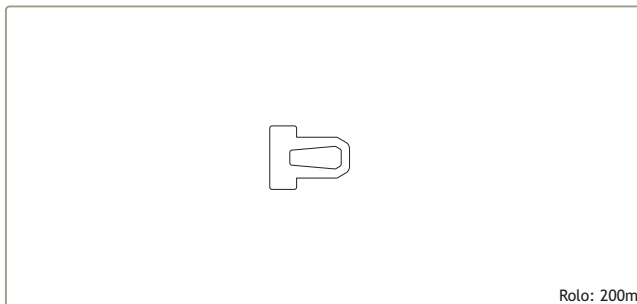

Rolo: 200m

208201

JUNTA VD 2413 PRT

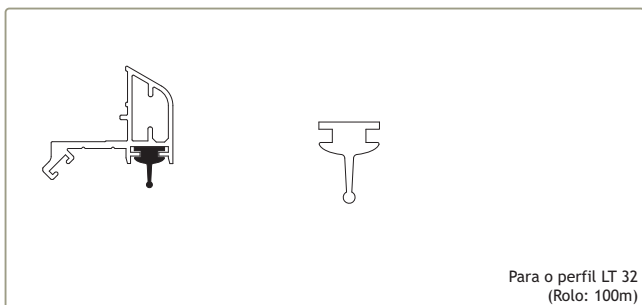

Para o perfil LT 32
(Rolo: 100m)

208246

JUNTA ENCAIXE 1140 PRT

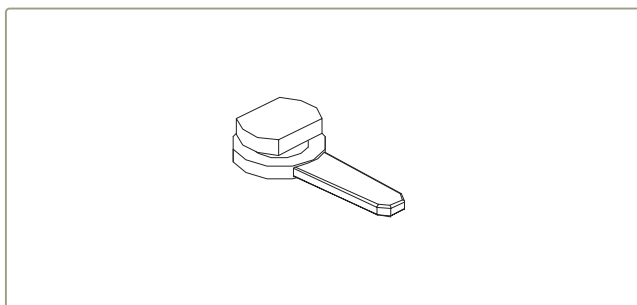

207204

PRESILHA VR 6052

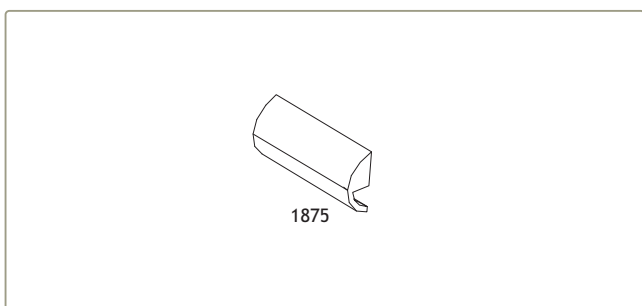

1875

210154

GOTEIRA 1875 Br/Pr

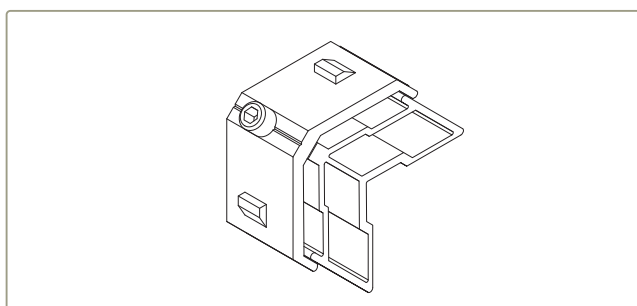

204728

ESQUADRO AT E. PEQUENO

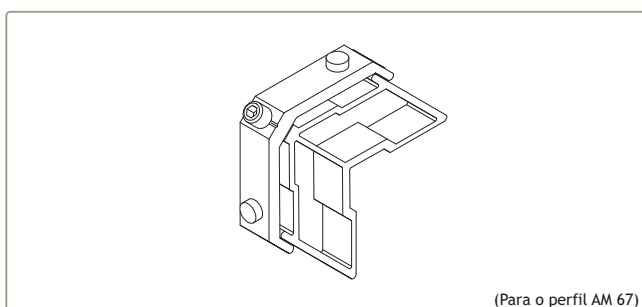

(Para o perfil AM 67)

204902

ESQUADRO 18-1135-C

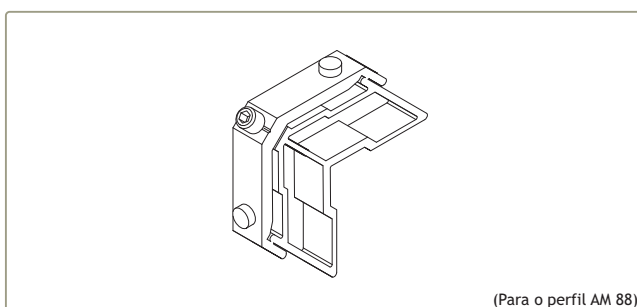

(Para o perfil AM 88)

204009

ESQUADRO 18-1130-C

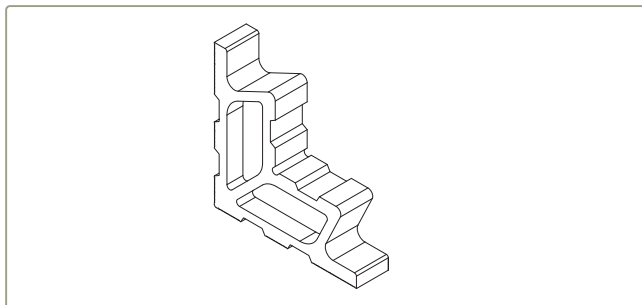

204257

ESQUADRO SA 35 CORTADO PEQUENO

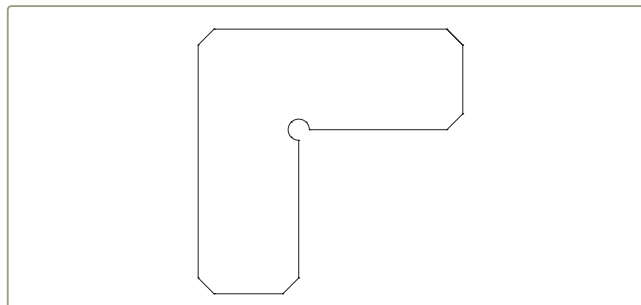

213246

CANTO CR S/SB

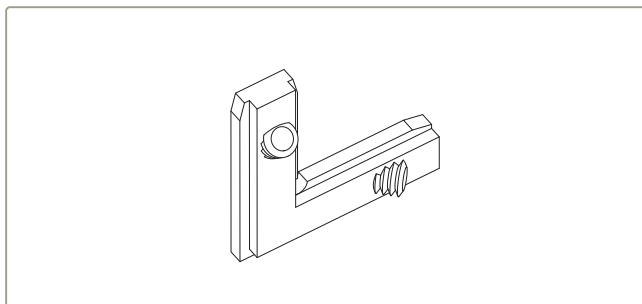

204131

ESQUADRO DE ALINHAMENTO C/APERTO

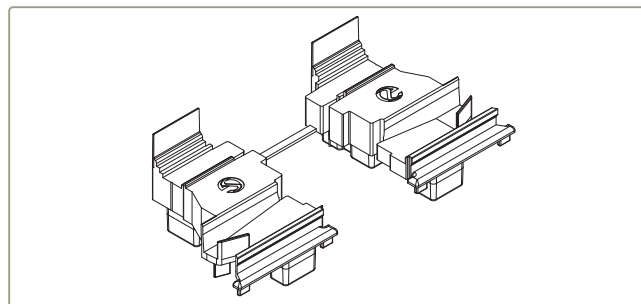

212062

CONJUNTO TOPO INVERSOR AM-B(rt)



(Aplicar em portas com a fechadura AS 2300)

200035

PUXADOR PORTA 20010 MR INOX

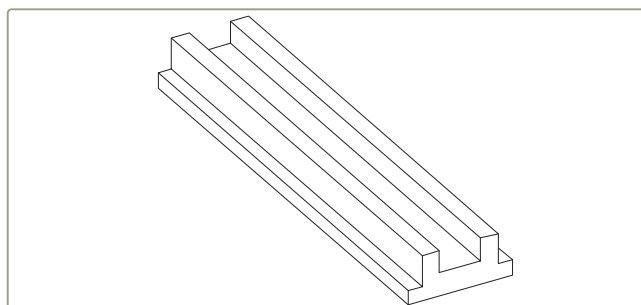

215144

PEÇA SUPORTE DOBRADIÇA VR 6058

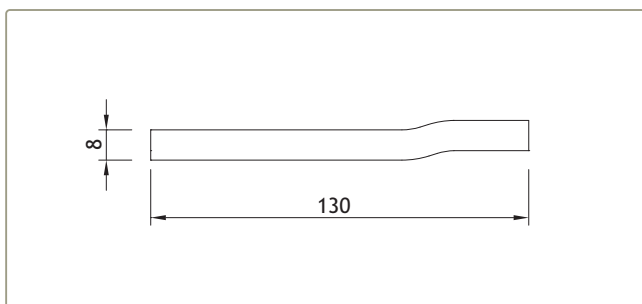

227302

QUADRA DESCENTRADA 130mm



(Aplicar em portas com a fechadura AS 2300)

200747

PUXADOR DUPLO 874.31 LATÃO



(Aplicar em janelas com a ferragem cremone)

200029

PUXADOR JANELA 20040 MR INOX

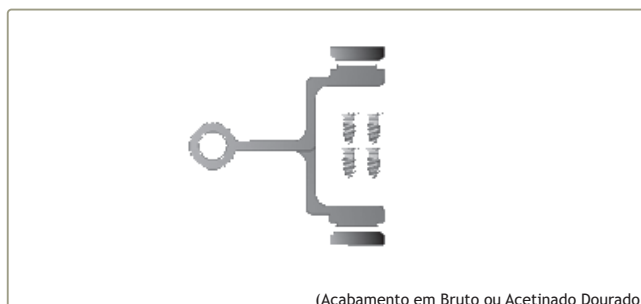

(Acabamento em Bruto ou Acetinado Dourado)

202222
202222

DOB. P/3 FOLHAS ASSL 199/W30 Bruto
DOB. P/3 FOLHAS ASSL 199/W30 Dourado



220195 ESPELHO P/SEG. 874.801 Dourado

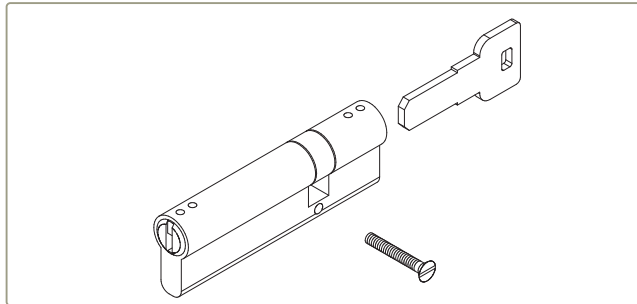

207401 CILINDRO BKS 80/50



220262 ESPELHO P/SEG. 10923 INOX



200784 PUXADOR DE JANELA MAN85LL LATÃO



200800 PUXADOR PORTA 138 PZ POL. DOURADO

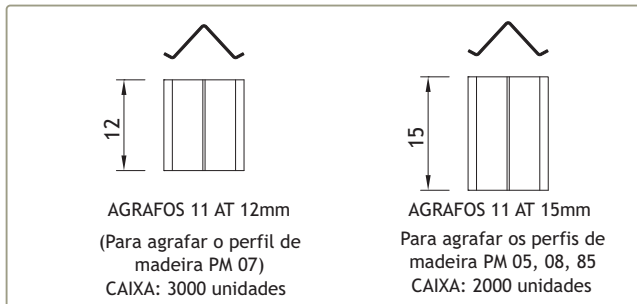

428003 AGRAFOS 11 AT 15mm
428002 AGRAFOS 11 AT 12mm

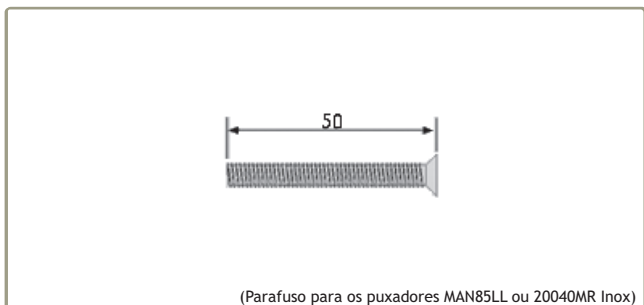

290028 PARAFUSO P/PUXADOR JANELA M5x50L

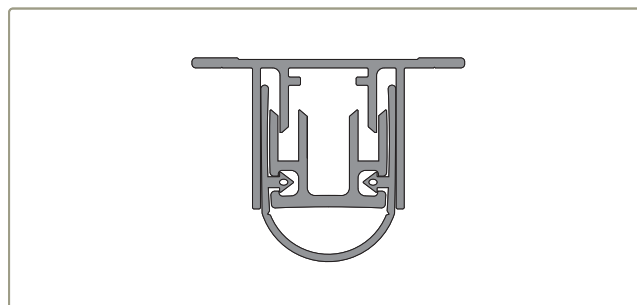

* KIT VEDAÇÃO INFERIOR DE PORTA

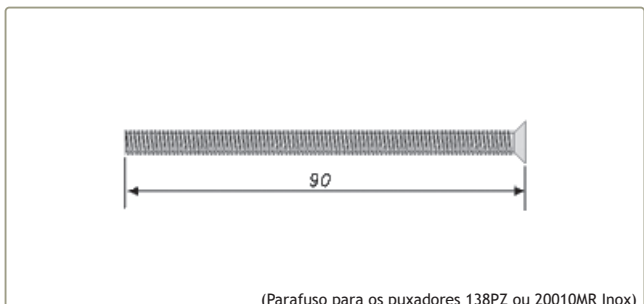

290258 PARAFUSO P/PUXADOR JANELA M5x90L

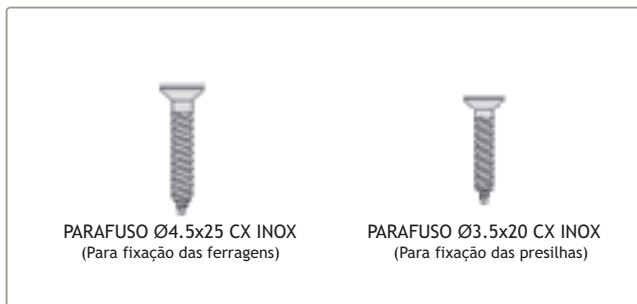

290002 PARAFUSO Ø4.5x25 CX INOX
290420 PARAFUSO Ø3.5x20 CX INOX

* ACESSÓRIO NÃO DISPONIBILIZADO PELO GRUPO SOSOARES

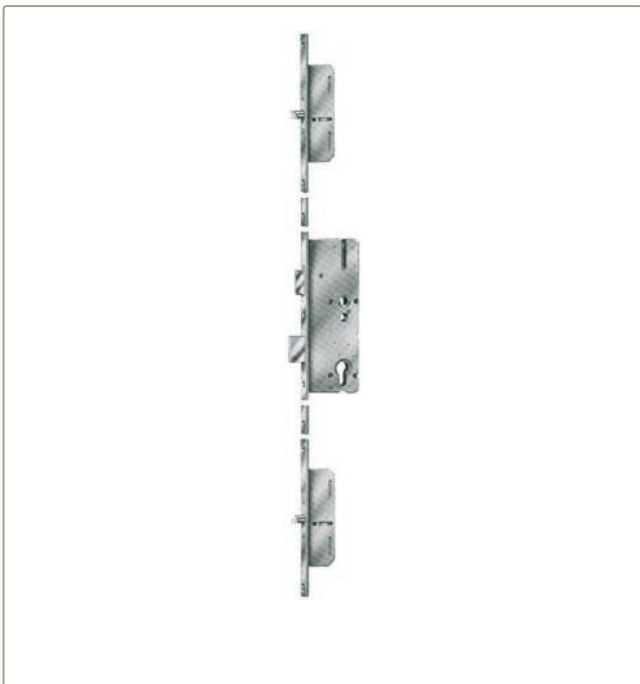

201039

FECHO AS2300/F16 DOUR. F/16/45/O

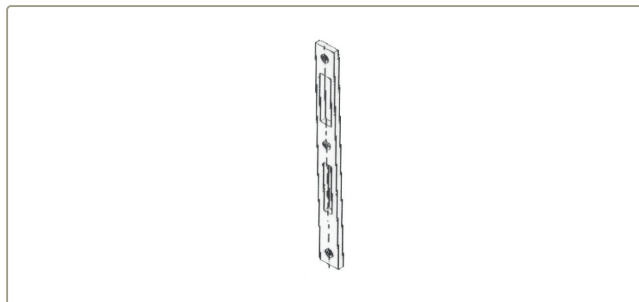

280001

TESTA (CHAPA) CENTRAL 8050-03-18CB

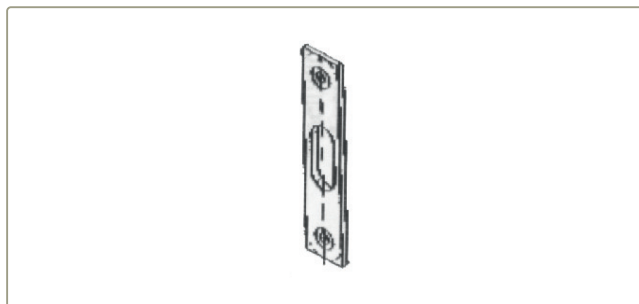

280247

TESTA (CHAPA) SUP/INF 2330-03-18CB

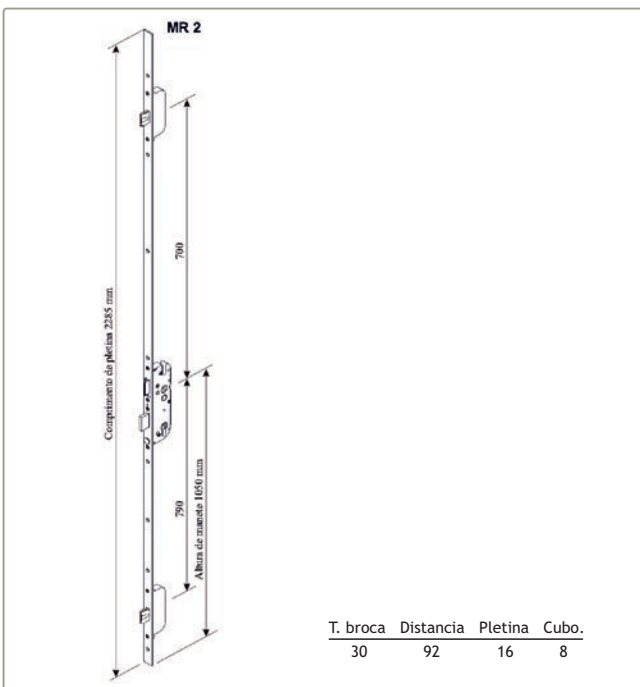

201056

FECHADURA T30mm/92



280014
280015

TESTA (CHAPA) CENTRAL Dir.
TESTA (CHAPA) CENTRAL Esq.

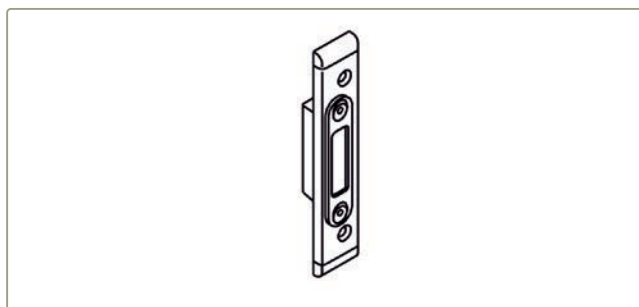

280013

TESTA (CHAPA) SUP/INF



208019

SELA JUNTAS 150gr. (Cinza)



208704

PRODUTO DE LIMPEZA DE ALUMÍNIO (1L) Transparente

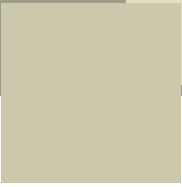



Pormenores de montagem

Assembly details
Détails de montage

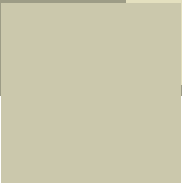

JANELA DE BATENTE DE 1 FOLHA - LINHA OVAL

1 LEAF CASEMENT WINDOW - OVAL MODEL

FENÊTRE À LA FRANÇAISE 1 VANTAIL - LIGNE OVALE

PERFIS - JANELA DE 1 FOLHA				
PROFILES - 1 LEAF WINDOW PROFILS - FENÊTRE À 1 VANTAIL				
REFERÊNCIA REFERENCE RÉFÉRENCE	CORTE HORIZONTAL HORIZONTAL DETAIL DÉTAIL HORIZONTAL	CORTE VERTICAL VERTICAL DETAIL DÉTAIL VERTICALE	QUANTIDADE QUANTITY QUANTITÉ	CORTE CUT COUPÉ
AM-67	L-6	H-6	2+2	
AM-65	L-96	H-96	2+2	
AM-90	L-188	H-188	2+2	
PM-67	L-6	H-6	2+2	
PM-65	L-96	H-96	2+2	
PM-90	L-196	H-196	2+2	

ACESSÓRIOS		
ACCESSORIES ACCESSOIRES		
CÓDIGO CODE	DESIGNAÇÃO DESIGNATION DÉSIGNATION	QUANTIDADE QUANTITY QUANTITÉ
210154	GOTEIRA 1875 DRIP GOUTTIÈRE	2
213246	CANTO CR S/SB ANGLE COIN	4
204901	ESQUADRO 18-1112-C BLOCKING BRACKET ÉQUERRE	8
24902	ESQUADRO 18-1135-C BLOCKING BRACKET ÉQUERRE	8
204131	ESQUADRO ALINHA. C/APERTO ALIGNMENT BRACKET ÉQUERRE	4
200029	PUXADOR 20040 HANDLE POIGNÉE	1
215144	PEÇA SUPORTE DOB. VR6058 HING BRACKET SUPPORT DE PALMELLE	2
218112	CAÇOS P/VIDRO 5mm GLAZING SHIM CALE POUR VITRAGE	12
207204	PRESILHA VR 6052 CLAMP CLAMEAU	(4L+4H)/200
290420	PARAFUSOS 3.5x20 CX INOX STAINLESS STEEL SCREWS VIS ACIER INOX	(4L+4H)/200
290028	PARAFUSOS M5x50L SCREWS VIS	2

PARA AS FERRAGENS, CONSULTAR GABINETE TÉCNICO
FOR HARDWARE, CONSULT TECHNICAL DEPARTMENT | POUR SERRURES, CONSULTÉ DÉPARTEMENT TECHNIQUE

VEDANTES		
SEALANTS JOINTS		
CÓDIGO CODE	DESIGNAÇÃO DESIGNATION DÉSIGNATION	QUANTIDADE QUANTITY QUANTITÉ
208399	VD 2400	2L+2H
208400	VD 2405	2L+2H
208008	VD 2051	2L+2H
208278	VD 2112	2L+2H
208289	VD 2055	2L+2H
208437	VD 2420	2L+2H
208435	VD 2415	2L+2H
208411	VD 2410	2L+2H
208413	VD 2411	2L+2H
VARIÁVEL VARIABLE	JUNTA INTERIOR GLAZING WEDGE GASKET JOINT INTÉRIEUR	2L+2H

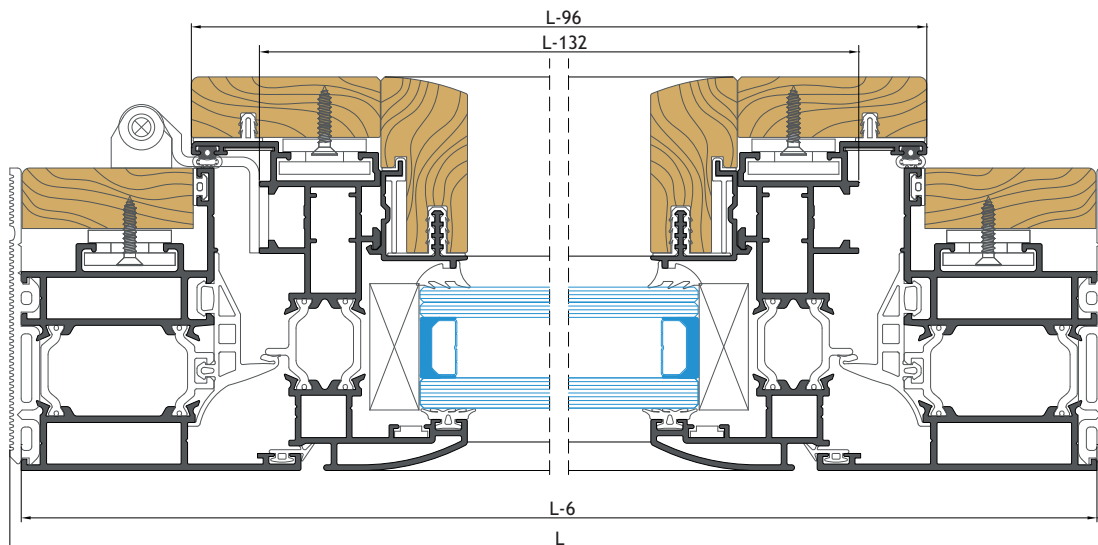
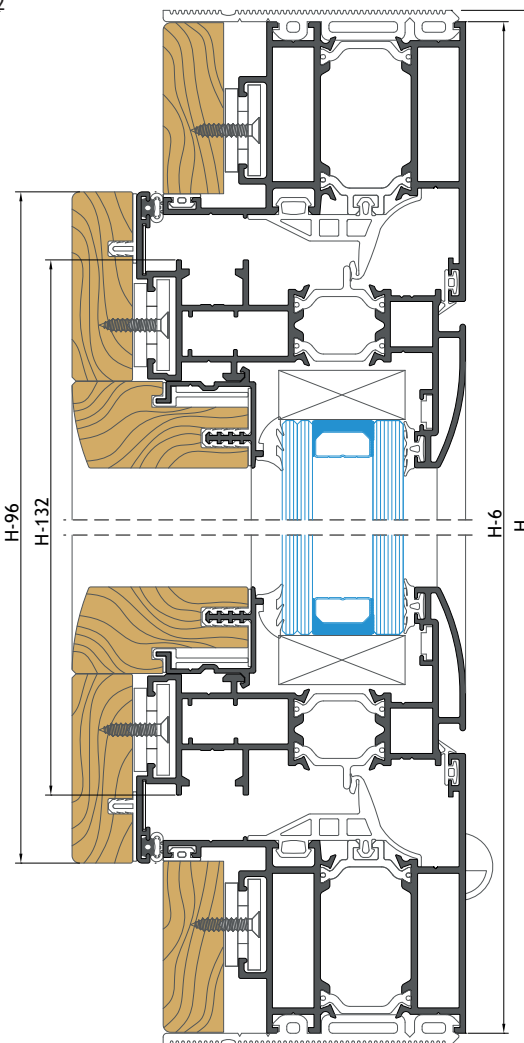
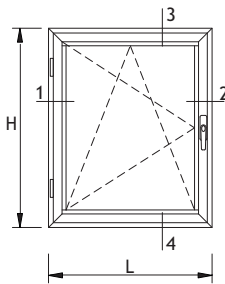

1

2

ESC: 1/2



JANELA DE BATENTE DE 2 FOLHAS - LINHA OVAL

2 LEAVES WINDOW - OVAL MODEL

FENÊTRE À LA FRANÇAISE 2 VANTAUX - LIGNE OVALE

PERFIS - JANELA DE 1 FOLHA				
PROFILES - 1 LEAF WINDOW PROFILS - FENÊTRE À 1 VANTAUX				
REFERÊNCIA REFERENCE RÉFÉRENCE	CORTE HORIZONTAL HORIZONTAL DETAIL DÉTAIL HORIZONTAL	CORTE VERTICAL VERTICAL DETAIL DÉTAIL VERTICALE	QUANTIDADE QUANTITY QUANTITÉ	CORTE CUT COUPÉ
AM-67	L-6	H-6	2+2	
AM-65	(L/2)-51	H-96	2+2	
AM-90	(L/2)-143.5	H-188	2+2	
AM-16	-	H-172	2+2	
PM-67	L-6	H-6	2+2	
PM-65	(L/2)-51	H-96	2+2	
PM-90	(L/2)-151	H-196	2+2	

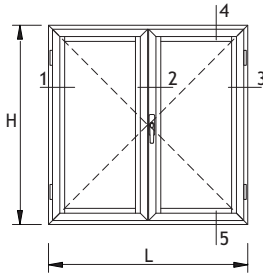

ACESSÓRIOS ACCESSORIES ACCESSOIRES		
CÓDIGO CODE	DESIGNAÇÃO DESIGNATION DÉSIGNATION	QUANTIDADE QUANTITY QUANTITÉ
210154	GOTEIRA 1875 DRIP GOUTTIÈRE	2
213246	CANTO CR S/SB ANGLE COIN	8
204901	ESQUADRO 18-1112-C BLOCKING BRACKET ÉQUERRE	16
24902	ESQUADRO 18-1135-C BLOCKING BRACKET ÉQUERRE	8
204131	ESQUADRO ALINHA. C/APERTO ALIGNMENT BRACKET ÉQUERRE	8
212062	CONJUNTO TOPO INV. AMB(rt) END-CAP KIT KIT DE EMBOUTE	8
200029	PUXADOR 20040 HANDLE POIGNÉE	1
215144	PEÇA SUPORTE DOB. VR6058 HING BRACKET SUPPORT DE PAUMELLE	4
218112	CALÇOS P/VIDRO 5mm GLAZING SHIM CALE POUR VITRAGE	24
207204	PRESILHA VR 6052 CLAMP CLAMEAU	(4L+6H)/200
290420	PARAFUSOS 3.5x20 CX INOX STAINLESS STEEL SCREWS VIS ACIER INOX	(4L+6H)/200
290028	PARAFUSOS M5x50L SCREWS VIS	2

PARA AS FERRAGENS, CONSULTAR GABINETE TÉCNICO
FOR HARDWARE, CONSULT TECHNICAL DEPARTMENT | POUR SERRURES, CONSULTÉ DÉPARTEMENT TECHNIQUE

VEDANTES SEALANTS JOINTS		
CÓDIGO CODE	DESIGNAÇÃO DESIGNATION DÉSIGNATION	QUANTIDADE QUANTITY QUANTITÉ
208399	VD 2400	2L+2H
208400	VD 2405	2L+3H
208008	VD 2051	2L+4H
208278	VD 2112	2L+4H
208289	VD 2055	2L+4H
208437	VD 2420	2L+4H
208435	VD 2415	2L+2H
208411	VD 2410	2L+4H
208413	VD 2411	2L+4H
208124	VD 2203	H
VARIÁVEL VARIABLE	JUNTA INTERIOR GLAZING WEDGE GASKET JOINT INTÉRIEUR	2L+4H

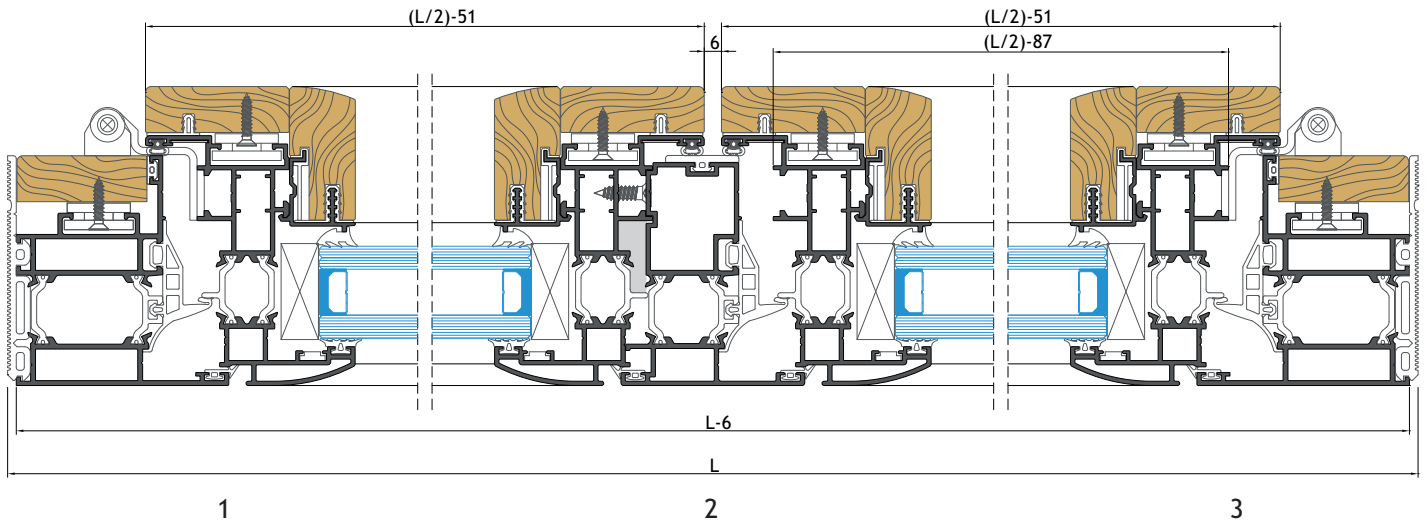
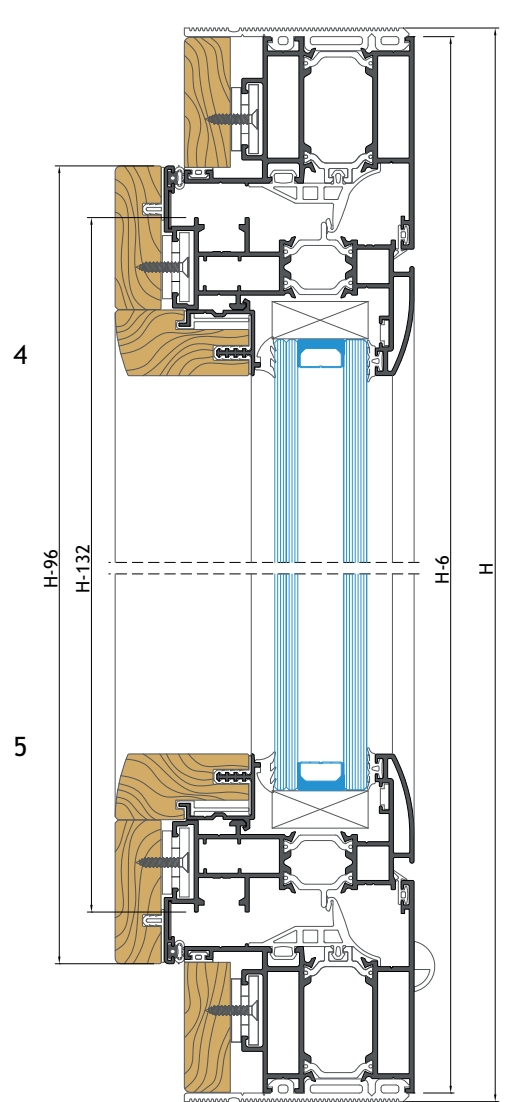

PORTA DE 1 FOLHA - ABERTURA PARA INTERIOR

1 LEAF DOOR - INWARD OPENING

PORTE DE 1 VANTAIL - OUVERTURE VERS L'INTÉRIEUR

PERFIS - JANELA DE 1 FOLHA PROFILES - 1 LEAF WINDOW PROFILS - FENÊTRE À 1 VANTAIL				
REFERÊNCIA REFERENCE RÉFÉRENCE	CORTE HORIZONTAL HORIZONTAL DETAIL DÉTAIL HORIZONTAL	CORTE VERTICAL VERTICAL DETAIL DÉTAIL VERTICALE	QUANTIDADE QUANTITY QUANTITÉ	CORTE CUT COUPÉ
AM-67	L-6	H-3	1+2	H V
AM-88	L-96	H-55	1+2	H V
AM-90	L-225	H-198	2+2	H V
AM-36	L-222	-	1	H V
PM-67	L-6	H-3	1+2	H V
PM-88	L-96	H-55	1+2	H V
PM-90	L-233	H-206	2+2	H V
PM-91	L-233	-	1	H V
PM-64	L-233	-	1	H V

ACESSÓRIOS ACCESSORIES ACCESSOIRES		
CÓDIGO CODE	DESIGNAÇÃO DESIGNATION DÉSIGNATION	QUANTIDADE QUANTITY QUANTITÉ
210154	GOTEIRA 1875 DRIP GOUTTIÈRE	2
213246	CANTO CR S/SB ANGLE COIN	2
204009	ESQUADRO 18-1130-C BLOCKING BRACKET ÉQUERRE	4
24902	ESQUADRO 18-1135-C BLOCKING BRACKET ÉQUERRE	4
204131	ESQUADRO ALINHA. C/APERTO ALIGNMENT BRACKET ÉQUERRE	2
215144	PEÇA SUPORTE DOB. VR6058 HING BRACKET SUPPORT DE PAUMELLE	4
218112	CALÇOS P/VIDRO 5mm GLAZING SHIM CALE POUR VITRAGE	12
207204	PRESILHA VR 6052 CLAMP CLAMEAU	(2L+4H)/200
290420	PARAFUSOS 3.5x20 CX INOX STAINLESS STEEL SCREWS VIS ACIER INOX	(2L+4H)/200
290258	PARAFUSOS M5x90L SCREWS VIS	2
200800	PUXADOR 138 PZ HANDLE POIGNÉE	1
207401	CILINDRO BKS 80/50 CYLINDER LOCK CYLINDRE DE SERRURE	1
207204	FECHADURA T30mm/92 LOCKER SERRURE	1
280014-Dir 280015-Esq	CHAPA TESTA CENTRAL DIR/ESQ STRAICKING PLATE GÂCHE	1
280013	PCHAPA TESTA SUP/INF STRAICKING PLATE GÂCHE	2
227302	QUADRA DESCEN. 130mm OFFSET SQUARE SHAFT BARRE CARRÉE DÉCENTRÉE	1

PARA AS FERRAGENS, CONSULTAR GABINETE TÉCNICO
FOR HARDWARE, CONSULT TECHNICAL DEPARTMENT | POUR SERRURES, CONSULTÉ DÉPARTEMENT TECHNIQUE

VEDANTES SEALANTS JOINTS		
CÓDIGO CODE	DESIGNAÇÃO DESIGNATION DÉSIGNATION	QUANTIDADE QUANTITY QUANTITÉ
208399	VD 2400	1L+2H
208400	VD 2405	1L+2H
208008	VD 2051	1L+2H
208278	VD 2112	1L+2H
208289	VD 2055	2L+2H
208437	VD 2420	1L+2H
208435	VD 2415	1L+2H
208411	VD 2410	3L+2H
208413	VD 2411	3L+2H
VARIÁVEL VARIABLE	JUNTA INTERIOR GLAZING WEDGE GASKET JOINT INTÉRIEUR	2L+2H
208194	VD 2202	2L

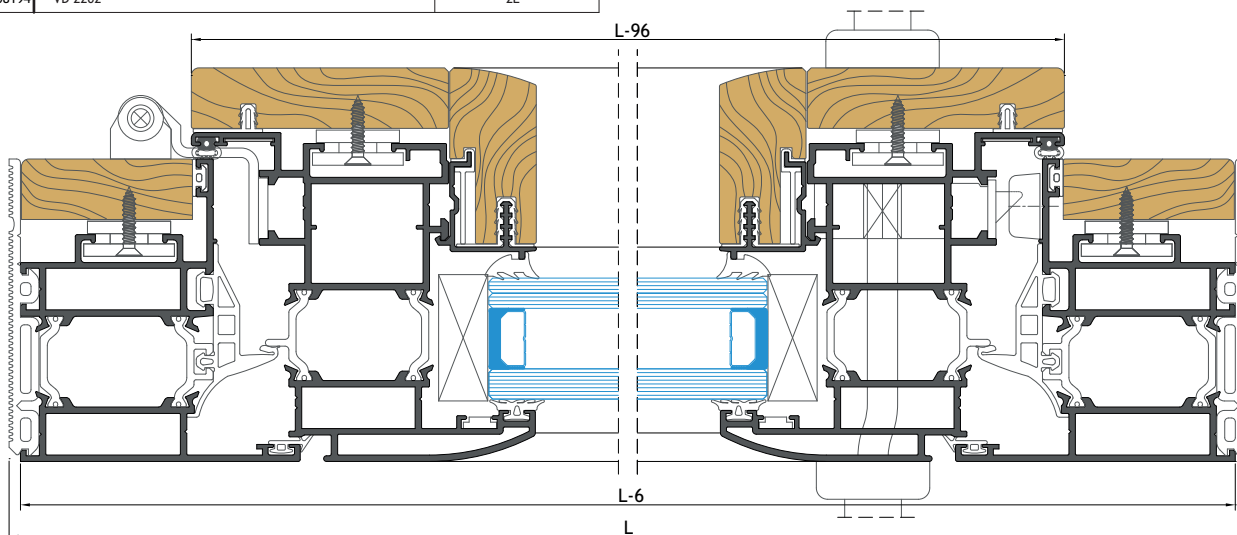
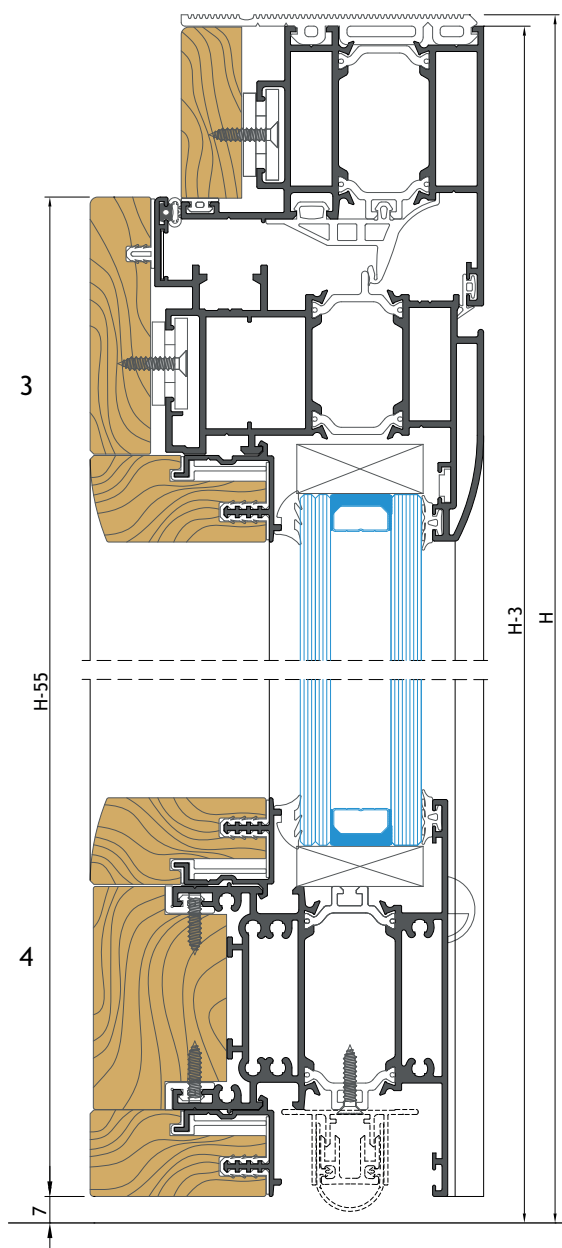
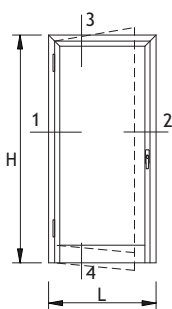

ESC: 1/2



PORTA DE 2 FOLHAS - ABERTURA PARA INTERIOR

2 LEAVES DOOR - INWARD OPENING

PORTE DE 2 VANTAUX - OUVERTURE VERS L'INTÉRIEUR

PERFIS - JANELA DE 1 FOLHA PROFILES - 1 LEAF WINDOW PROFIS - FENÊTRE À 1 VANTAIL				
REFERÊNCIA REFERENCE RÉFÉRENCE	CORTE HORIZONTAL HORIZONTAL DETAIL DÉTAIL HORIZONTAL	CORTE VERTICAL VERTICAL DETAIL DÉTAIL VERTICALE	QUANTIDADE QUANTITY QUANTITÉ	CORTE CUT COUPÉ
AM-67	L-6	H-3	1+2	H V
AM-88	(L/2)-51	H-55	2+4	H V
AM-90	(L/2)-180	H-198	4+4	V
AM-36	(L/2)-177	-	2	
AM-16	-	H-93	1	
PM-67	L-6	H-3	2+4	H V
PM-88	(L/2)-51	H-55	2+4	H V
PM-90	(L/2)-188	H-206	4+4	
PM-91	(L/2)-188	-	2	
PM-64	(L/2)-188	-	2	

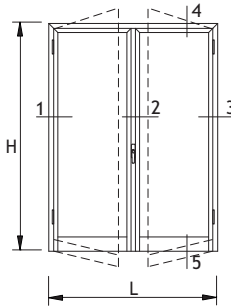

ACESSÓRIOS ACCESSORIES ACCESSOIRES		
CÓDIGO CODE	DESIGNAÇÃO DESIGNATION DÉSIGNATION	QUANTIDADE QUANTITY QUANTITÉ
210154	GOTEIRA 1875 DRIP GOUTTIÈRE	4
213246	CANTO CR S/SB ANGLE COIN	4
204009	ESQUADRO 18-1130-C BLOCKING BRACKET ÉQUERRE	8
24902	ESQUADRO 18-1135-C BLOCKING BRACKET ÉQUERRE	8
204131	ESQUADRO ALINHA. C/APERTO ALIGNMENT BRACKET ÉQUERRE	4
215144	PEÇA SUPORTE DOB. VR6058 HING BRACKET SUPPORT DE PAUMELLE	8
218112	CALÇOS P/VIDRO 5mm GLAZING SHIM CALE POUR VITRAGE	24
207204	PRESILHA VR 6052 CLAMP CLAMEAU	(2L+6H)/200
290420	PARAFUSOS 3.5x20 CX INOX STAINLESS STEEL SCREWS VIS ACIER INOX	(2L+6H)/200
290258	PARAFUSOS M5x90L SCREWS VIS	2
200800	PUXADOR 138 PZ HANDLE POIGNÉE	1
207401	CILINDRO BKS 80/50 CYLINDER LOCK CYLINDRE DE SERRURE	1
207204	FECHADURA T30mm/92 LOCKER SERRURE	1
280014-Dir 280015-Esq	CHAPA TESTA CENTRAL DIR/ESQ STRAICKING PLATE GÂCHE	1
280013	PCHAPA TESTA SUP/INF STRAICKING PLATE GÂCHE	2
227302	QUADRA DESCEN. 130mm OFFSET SQUARE SHAFT BARRE CARRÉE DÉCENTRÉE	1

PARA AS FERRAGENS, CONSULTAR GABINETE TÉCNICO
FOR HARDWARE, CONSULT TECHNICAL DEPARTMENT | POUR SERRURES, CONSULTÉ DÉPARTEMENT TECHNIQUE

VEDANTES SEALANTS JOINTS		
CÓDIGO CODE	DESIGNAÇÃO DESIGNATION DÉSIGNATION	QUANTIDADE QUANTITY QUANTITÉ
208399	VD 2400	1L+2H
208400	VD 2405	1L+3H
208008	VD 2051	1L+3H
208278	VD 2112	1L+3H
208289	VD 2055	2L+4H
208437	VD 2420	1L+4H
208435	VD 2415	1L+2H
208411	VD 2410	3L+4H
208413	VD 2411	3L+4H
VARIÁVEL VARIABLE	JUNTA INTERIOR GLAZING WEDGE GASKET JOINT INTÉRIEUR	2L+4H
208194	VD 2202	2L

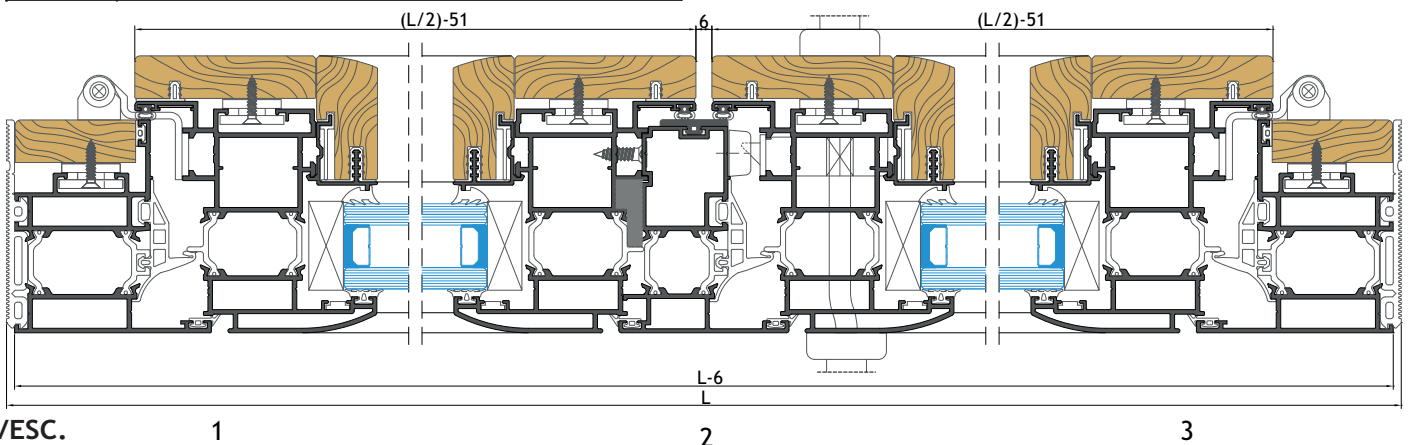
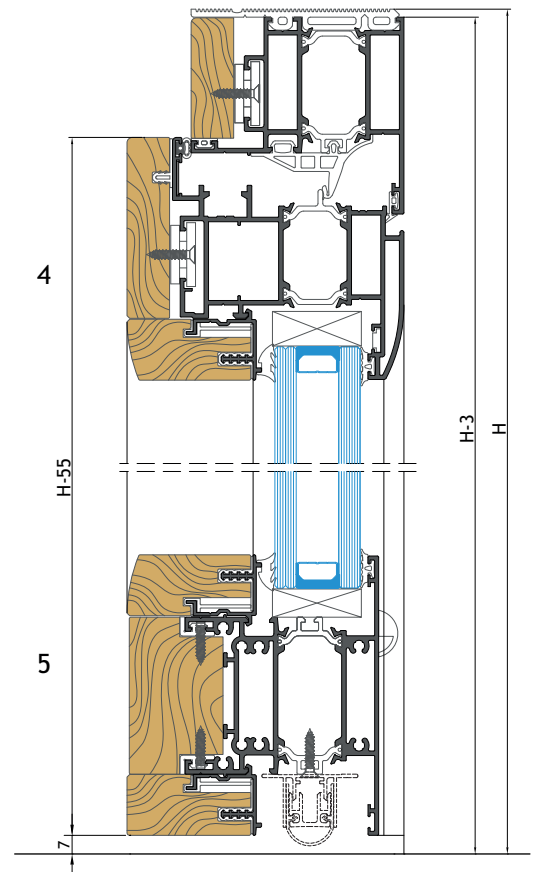

S/ESC.

PORTA DE ABERTURA PARA EXTERIOR
 OUTWARD OPENING DOOR
 PORTE DE OUVERTURE VERS L'EXTÉRIEUR

PERFIS - PORTA DE 1 FOLHA				
PROFILES - 1 LEAF DOOR PROFILS - PORTE À 1 VANTAIL				
REFERÊNCIA REFERENCE RÉFÉRENCE	CORTE HORIZONTAL HORIZONTAL DETAIL DÉTAIL HORIZONTALAILE	CORTE VERTICAL VERTICAL DETAIL DÉTAIL VERTICALE	QUANTIDADE QUANTITY QUANTITÉ	CORTE CUT CUT COUPÉ
AM-68	L	H	1+2	H V
AM-69	L-90	H-52	1+2	H V
AM-90	L-251	H-213	2+2	H V
AM-36	L-249	-	1	H V
PM-68	L	H	1+2	H V
PM-69	L-160	H-102	1+2	H V
PM-93	L-259	H-172	2+2	H V
PM-14	L-249	-	1	H V
MAD Nº1	L-2	-	1	H V

PERFIS - PORTA DE 2 FOLHAS				
PROFILES - 2 LEAVES DOOR PROFILS - PORTE À 2 VANTAUX				
REFERÊNCIA REFERENCE RÉFÉRENCE	CORTE HORIZONTAL HORIZONTAL DETAIL DÉTAIL HORIZONTALAILE	CORTE VERTICAL VERTICAL DETAIL DÉTAIL VERTICALE	QUANTIDADE QUANTITY QUANTITÉ	CORTE CUT CUT COUPÉ
AM-68	L	H	1+2	H V
AM-69	(L/2)-96	H-52	1+2	H V
AM-90	(L/2)-419	H-213	2+2	H V
AM-36	(L/2)-419	-	1	H V
AM-24	-	H-162	1	H V
PM-68	L	H	1+2	H V
PM-69	(L/2)-236	H-102	1+2	H V
PM-93	(L/2)-434	H-172	2+2	H V
PM-24	-	H-162	1	H V
PM-14	(L/2)-434	-	1	H V
MAD Nº1	(L/2)-434	-	1	H V

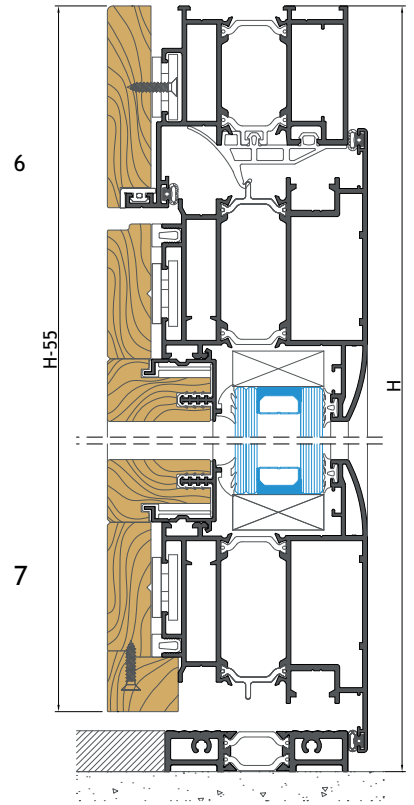
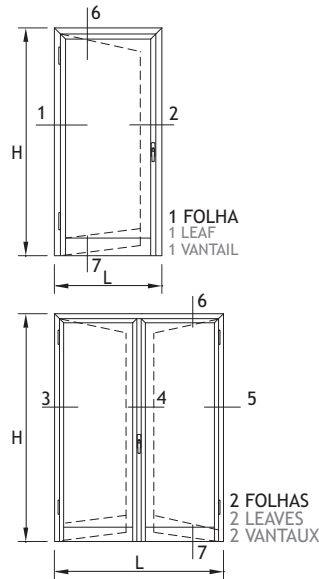

ALTERNATIVA | ALTERNATIVE | ALTERNATIVE

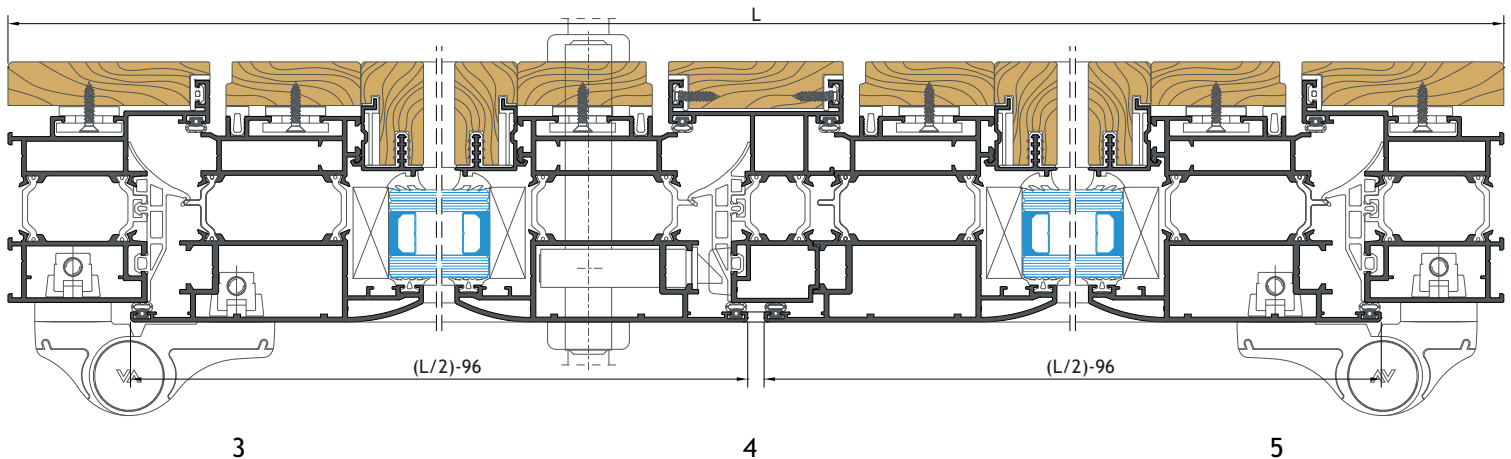
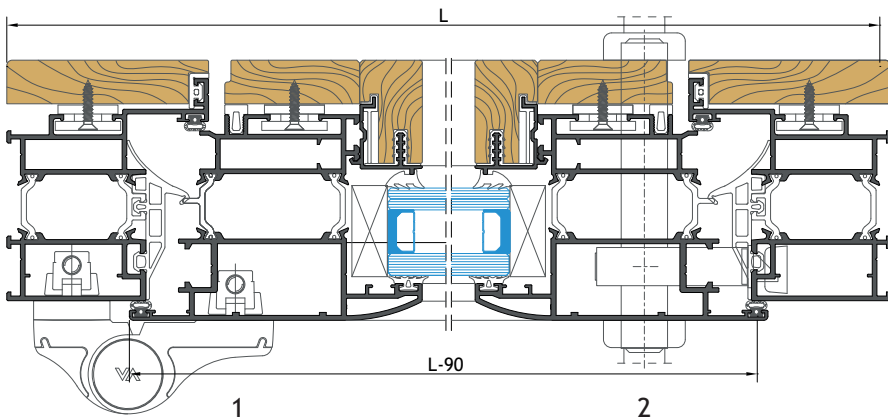
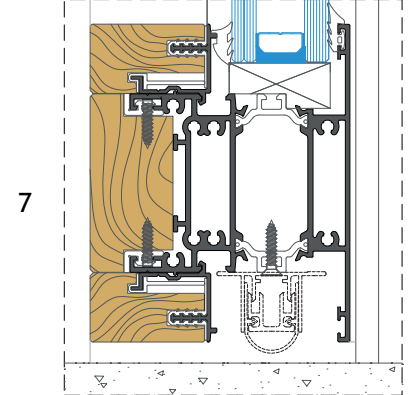

PORMENOR CONSTRUTIVO - COM SOLEIRA AM-50

DETAIL - WITH DRILL AM-50

DÉTAIL - AVEC SEUIL AM-50

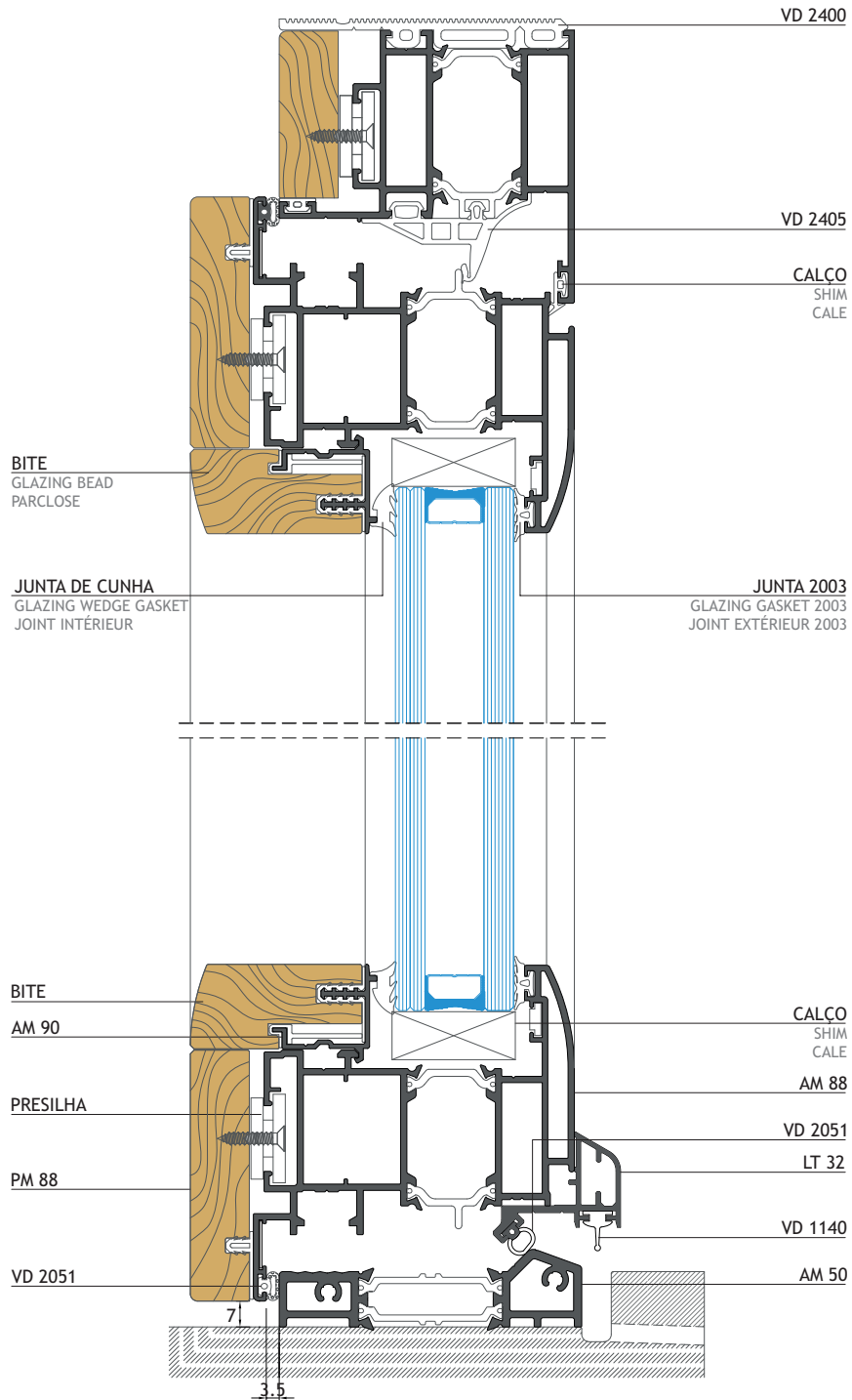





SISTEMAS
EURO 2000®
PERFIS DE ALUMÍNIO E VIDROS PARA ARQUITECTURA

SOSOARES

Rua do Campo Alegre, 474
4150-170 Porto
T +351 226 096 709 | F +351 226 005 642
E comercial@sosoares.pt

METALFER

Travessa do Bolegão, 146
Apartado 1
3754-904 Fermentelos
T +351 234 729 740 | F +351 234 729 741
E metalfer@sosoares.pt

ALFA SUL

EN Lisboa-Sintra Km 14
Apartado 156
2726-936 Mem Martins
T +351 219 265 090 | F +351 219 265 098
E alfa.sul@sosoares.pt

ALULIDER

Pavilhão Industrial H - Plataforma 13D
Zona Franca Industrial
9200-047 Caniçal - Madeira
T +351 291 960 494 | F +351 291 960 497
E alulider@sosoares.pt

PERFIS OEIRAS

Rua da Colónia - Quinta da Cardoso
Apartado 214 - Abrunheira
2711-952 Sintra
T +351 219 156 660 | F +351 219 156 661
E perfis.oeiras@sosoares.pt

www.sosoares.pt

