



sistema de batente de 56mm com corte térmico

56mm opening system with thermal break

système d'ouvrant de 56mm à rupture de pont thermique



SISTEMAS  
**EURO 2000**<sup>®</sup>  
PERFIS DE ALUMÍNIO E VIDROS PARA ARQUITECTURA



## Características do Sistema

### System features

### Caractéristiques du système



Reflexo do aperfeiçoamento aos sistemas de batente surge o sistema IT com uma secção intermédia de 56mm. Baseado no pressuposto de melhoramento das prestações térmicas e acústicas mas mantendo o factor competitivo, este sistema foi desenvolvido com o objectivo de oferecer uma excelente solução para obras de gama corrente, garantindo uma excelente relação qualidade/preço.”

Reflection of improving to the jamb systems arises the IT system with an intermediate section of 56mm. Based on the assumption of improved thermal and acoustic performance while maintaining the competitive factor, this system was developed with the aim to offer an excellent solution to works of current range, ensuring excellent quality / price ratio.

Reflet de l'amélioration des systèmes battante, surgit le système IT avec une section intermédiaire de 56mm. Basé sur l'hypothèse d'amélioration de la performance thermique et acoustique tout en conservant le facteur de compétitivité, ce système a été développé dans le but d'offrir une excellente solution pour les travaux de la gamme actuelle, assurant un excellent rapport qualité / prix.

<b>Apresentação:</b>	<b>Reta   Oval</b>
Presentation	Straight   Oval
Présentation	Droite   Ovale
<b>Dimensões:</b>	<b>Aro Fixo: 56mm</b>
Dimensions	Fixed frame
Dimension	Cadre dormant
	<b>Aro Móvel: 63mm</b>
	Mobile frame
	Cadre ouvrant
<b>Bites:</b>	<b>Retos ou Redondos</b>
Glazing beads	Straight or Round
Parcloses	Droite ou Arrondie
<b>Enchimento:</b>	<b>De 4 a 43mm</b>
Filling	From 4 to 43mm
Remplissage	De 4 à 43mm
<b>Cortes:</b>	<b>45°   90°</b>
Cuts	
Coupes	
<b>Vedação:</b>	<b>Junta em EPDM</b>
Insulation	EPDM joints
Étanchéité	Joint en EPDM
<b>União:</b>	<b>Exterior: De várias dimensões</b>
Joint	<b>Interior: Com esquadros de bloqueio e uniões de travessa</b>
Union	Outer: Several dimensions   Inner: blocking brackets and transoms unions
	Extérieur: Diverses dimensions   Intérieur: Équerres de verrouillage et unions des traverses
<b>Poliamida:</b>	<b>Aro fixo: 24mm   Aro móvel: 20mm</b>
Polyamide	Fixed frame   Mobile frame
Poliamide	Cadre dormant   Cadre ouvrant
<b>Peso máximo:</b>	<b>Janela batente (int./ext. 1   2 folhas) - 150 Kg/folha   leaf   vantail</b>
Maximum weight	Casement (in/out 1   2 leaves)   Fenêtre à la française (int./ext. 1   2 vantaux)
Poids maximale	<b>Porta batente (int./ext. 1   2 folhas) - 180 Kg/folha   leaf   vantail</b>
	French door (in/out 1   2 leaves)   Porte (int./ext. 1   2 vantaux)
	<b>Oscilo-batente - 150 Kg/folha   leaf   vantail</b>
	Tilt and turn   Oscillo-Battant
	<b>Oscilo-paralela - 160 Kg/folha   leaf   vantail</b>
	Tilt and slide   Oscillo-coulissant
	<b>Projetante - 120 Kg/folha   leaf   vantail</b>
	Awning   À l'italienne
	<b>Pivotante Vertical - 175 Kg/folha   leaf   vantail</b>
	Center pivot hvertical   Pivotante
	<b>Pivotante Horizontal - 175 Kg/folha   leaf   vantail</b>
	Center pivot horizontal   Basculante
	<b>Basculante - 70 Kg/folha   leaf   vantail</b>
	Hopper   À soufflet
	<b>Harmónio - 80 Kg/folha   leaf   vantail</b>
	Fold   Repliable
<b>Acabamentos:</b>	<b>Lacados   Anodizados   Bicolores</b>
Finishes	Powder coating   Anodizing   Bicolour
Finitions	Laqué   Anodisé   Bicolore



Licença nº. 1406 - Metalfer  
Licença nº. 1411 - Alfa Ul



Licença nº. 809

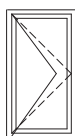

**Batente int|ext 1|2 folhas**  
casement in|out 1|2 leaves  
française int|ext 1|2 vantaux

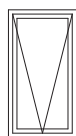

**Projetante**  
awning  
à l'italienne

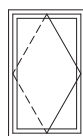

**Pivotante vertical**  
center pivot vert.  
pivotante

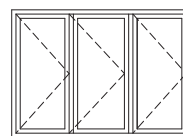

**Harmónio 3|4|5|6|7 folhas**  
fold 3|4|5|6|7 leaves  
repliable 3|4|5|6|7 vantaux



**Oscilo-batente 1|2 folhas**  
tilt and turn 1|2 leaves  
oscillo-battant 1|2 vantaux

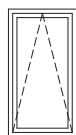

**Basculante**  
hopper  
à soufflet

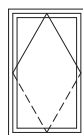

**Pivotante horizontal**  
center pivot horiz.  
basculante

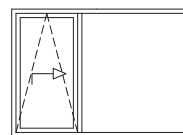

**Oscilo-paralela**  
tilt and slide  
oscillo-coulissant

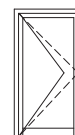

**Porta | Door | Porte**  
**Batente int|ext 1|2 folhas**  
door in|out 1|2 leaves  
française int|ext 1|2 vantaux



## Desempenho do sistema

System performance

Performance du système

### Marcação CE - Resultados previstos

CE Marking - Predicted results

Marquage CE - Résultats prévu

NP EN 14351-1

Janela 2 folhas com 1.60x1.40m

Vidro : 8 + 16 + 8

2 leaves window 1.60 x 1.40m

Glass: 8 + 16 + 18

Fenêtre 2 vantaux 1.60m x 1.40m

Verre: 8 + 16 + 8

#### Permeabilidade ao AR

AIR Permeability

Perméabilité à l'AIR

4

#### Estanquidade à ÁGUA

WATER Tightness

Étanchéité à l'EAU

E900

#### Resistência ao VENTO

WIND Resistance

Résistance au VENT

C5

#### Coef. Transm. TÉRMICA

THERMAL Transmittance

Coef. de Transmission THERMIQUE

**Uw = 1,74 W/m<sup>2</sup> K**Ug = 1,1W/m<sup>2</sup> K (Janela 2 folhas com 1,60x1,40m)Ug = 1,1W/m<sup>2</sup>K (2 leaves window with 1,60x1,40m)Ug = 1,1W/m<sup>2</sup>K (Fenêtre de 2 vantaux avec 1,60x1,40m)

#### Isolamento ACÚSTICO

ACOUSTIC Insulation

Isolation ACOUSTIQUE

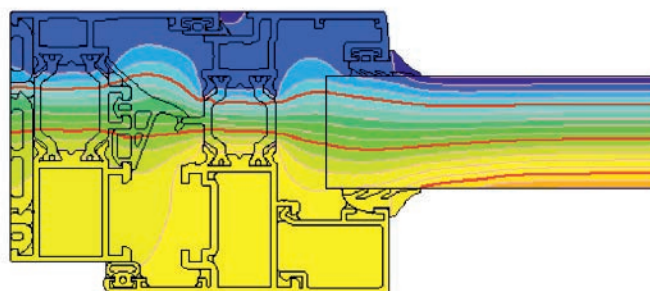
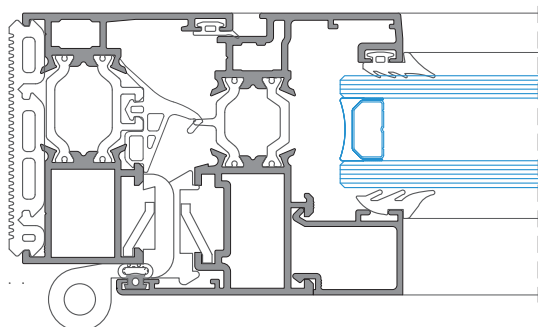
**Rw janela(dB)= 36dB**Rw (IGU) = 36dB, área ≤ 2,70m<sup>2</sup>Rw (IGU) = 36dB, aire ≤ 2,70m<sup>2</sup>Rw (IGU)=36dB, aire ≤ 2,70m<sup>2</sup>



5

## Listagem de perfis

Profiles list

Liste des profils

23

## Acessórios

Accessories

Accessoires

45

## Pormenores de montagem

Assembly details

Détails de montage



## Listagem de perfis

Profiles list

Liste des profils

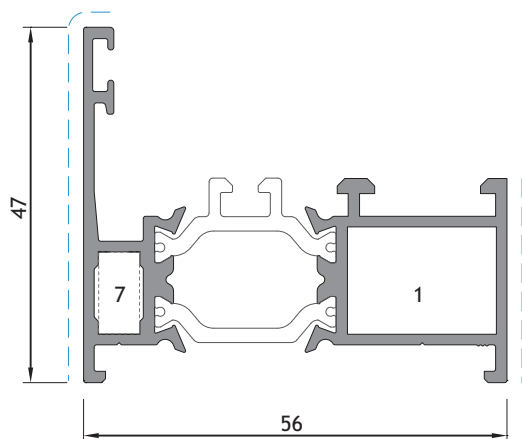

IT 01

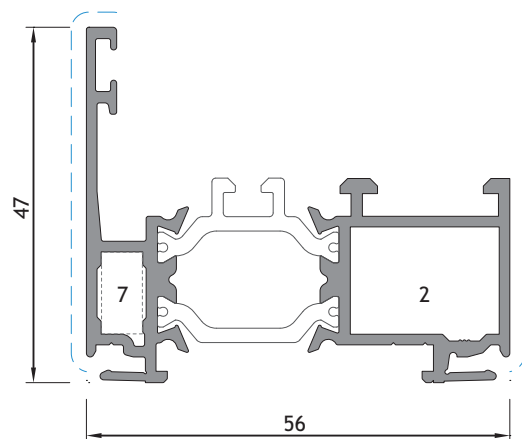

IT 51

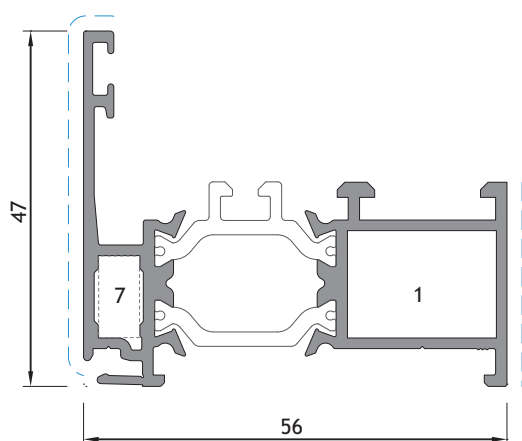

IT 31

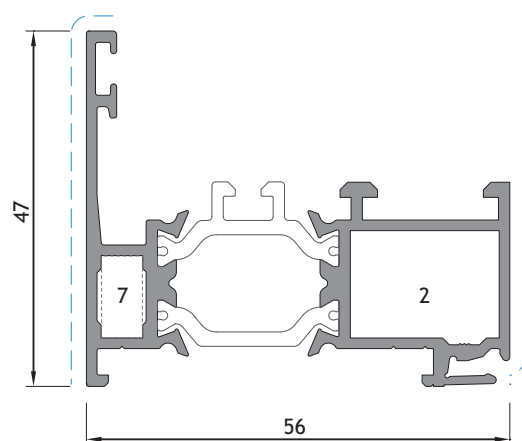

IT 41

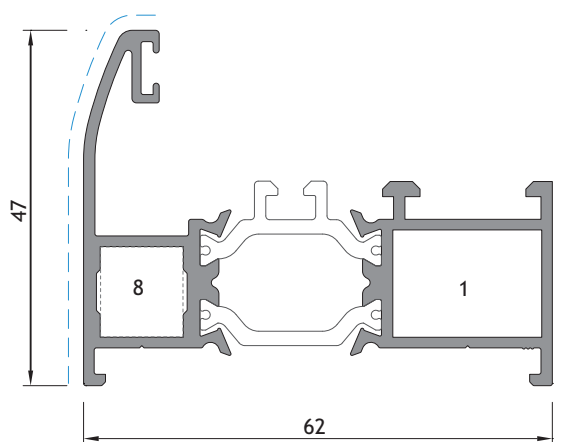

IT 38

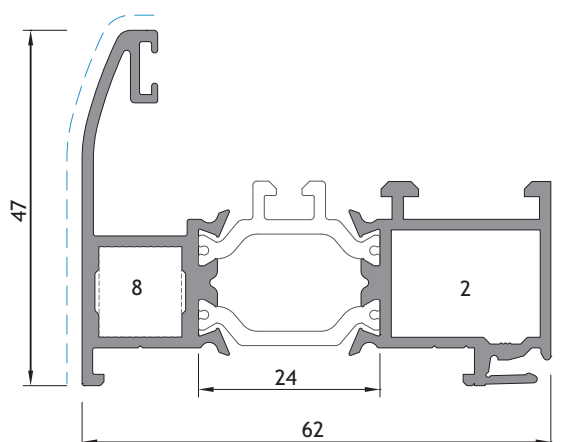

IT 28



1 - ESQUADRO IT/ST Nº 1  
6 - ESQUADRO IT/ST Nº 6  
11 - ESQUADRO AT E. G.

2 - ESQUADRO IT/ST Nº 2  
7 - CANTO CR 0018 + PINOS PEQ.  
12 - ESQUADRO AT E.P.

3 - ESQUADRO IT/ST Nº 3  
8 - ESQUADRO 18-1112-C  
13 - ESQUADRO 18-1414-C

4 - ESQUADRO IT/ST Nº 4  
9 - CANTO CR 0182 + PINOS GR.  
14 - ESQUADRO 1108

5 - ESQUADRO IT/ST Nº 5  
10 - ESQUADRO 18-1130-C  
15 - ESQUADRO 26-2537-140

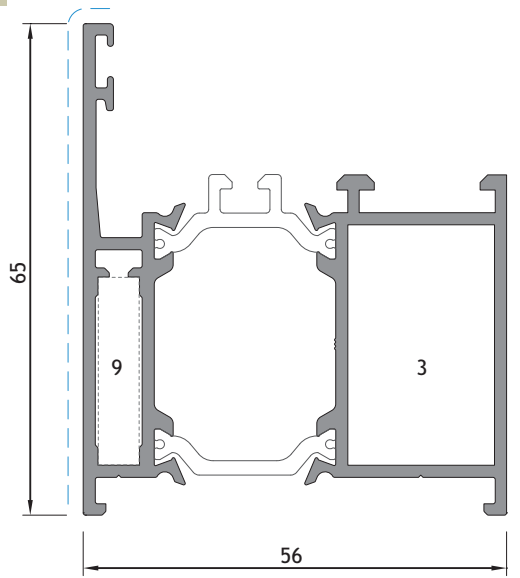

IT 07

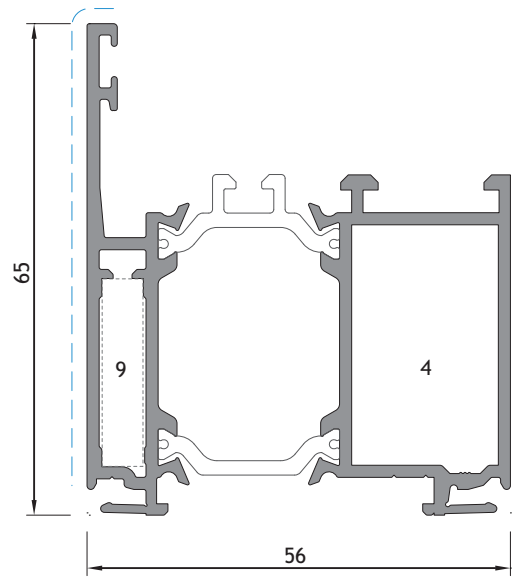

IT 57

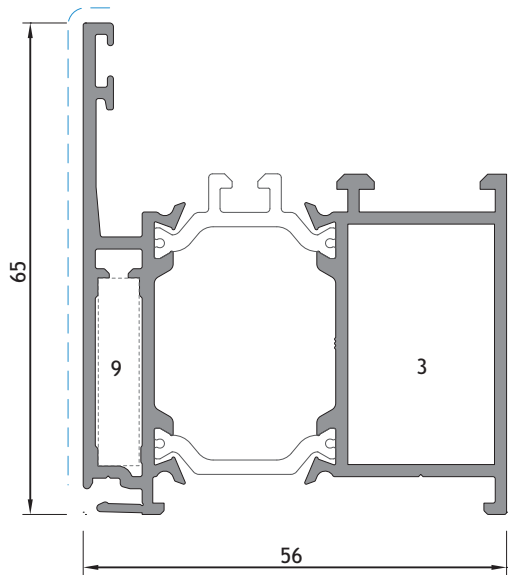

IT 67

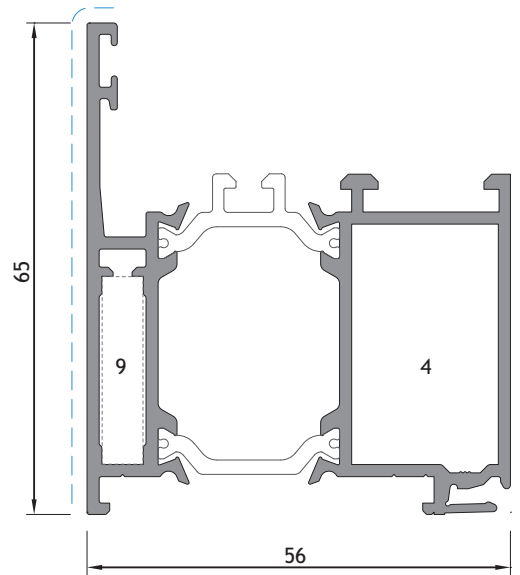

IT 47

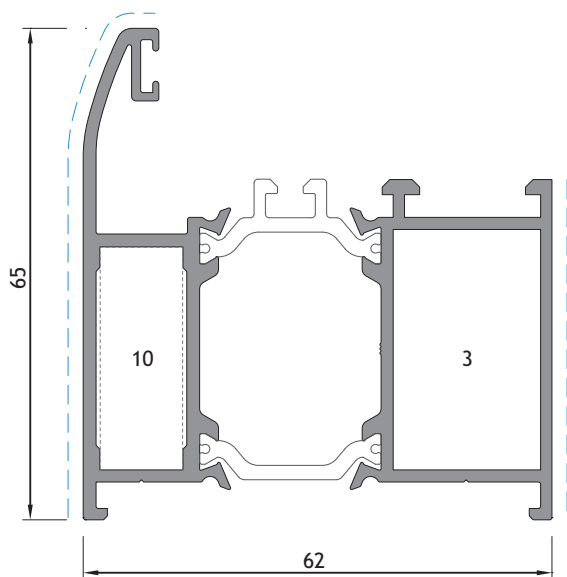

IT 56

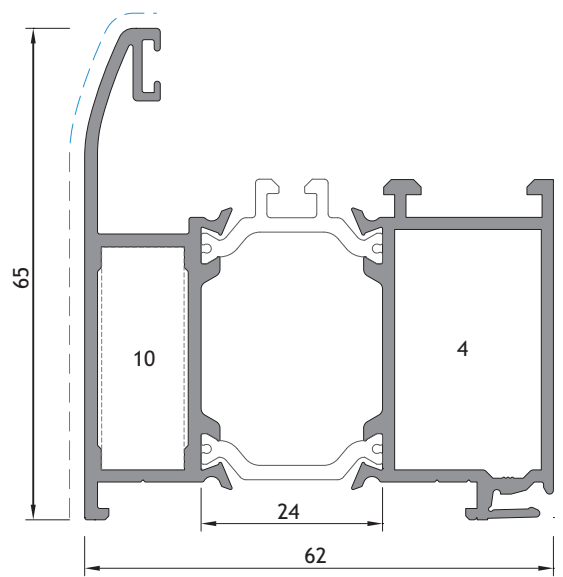

IT 69

1 - ESQUADRO IT/ST Nº 1  
6 - ESQUADRO IT/ST Nº 6  
11 - ESQUADRO AT E. G.

2 - ESQUADRO IT/ST Nº 2  
7 - CANTO CR 0018 + PINOS PEQ.  
12 - ESQUADRO AT E.P.

3 - ESQUADRO IT/ST Nº 3  
8 - ESQUADRO 18-1112-C  
13 - ESQUADRO 18-1414-C

4 - ESQUADRO IT/ST Nº 4  
9 - CANTO CR 0182 + PINOS GR.  
14 - ESQUADRO 1108

5 - ESQUADRO IT/ST Nº 5  
10 - ESQUADRO 18-1130-C  
15 - ESQUADRO 26-2537-140



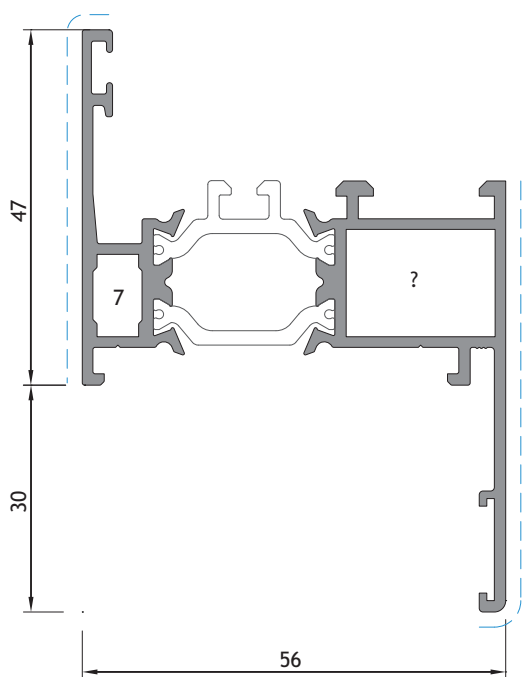

IT 81

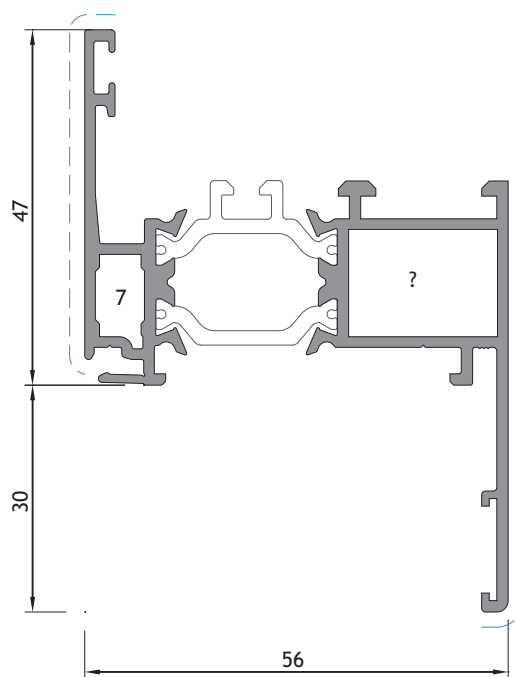

IT 61

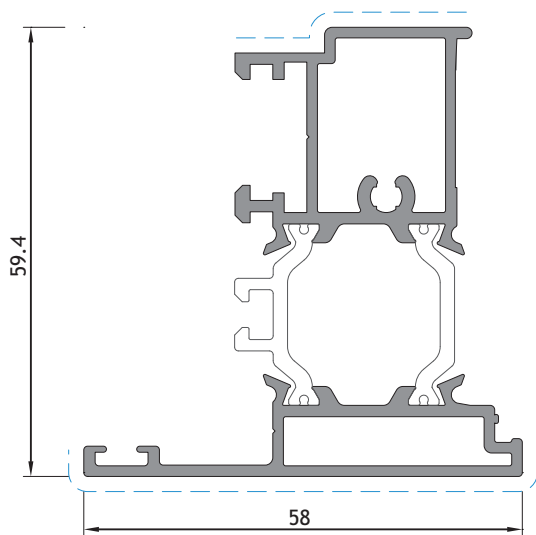

IT 06

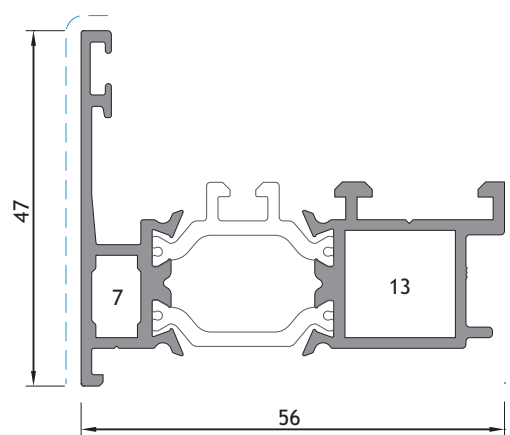

IT 83



1 - ESQUADRO IT/ST Nº 1  
6 - ESQUADRO IT/ST Nº 6  
11 - ESQUADRO AT E. G.

2 - ESQUADRO IT/ST Nº 2  
7 - CANTO CR 0018 + PINOS PEQ.  
12 - ESQUADRO AT E.P.

3 - ESQUADRO IT/ST Nº 3  
8 - ESQUADRO 18-1112-C  
13 - ESQUADRO 18-1414-C

4 - ESQUADRO IT/ST Nº 4  
9 - CANTO CR 0182 + PINOS GR.  
14 - ESQUADRO 1108

5 - ESQUADRO IT/ST Nº 5  
10 - ESQUADRO 18-1130-C  
15 - ESQUADRO 26-2537-140

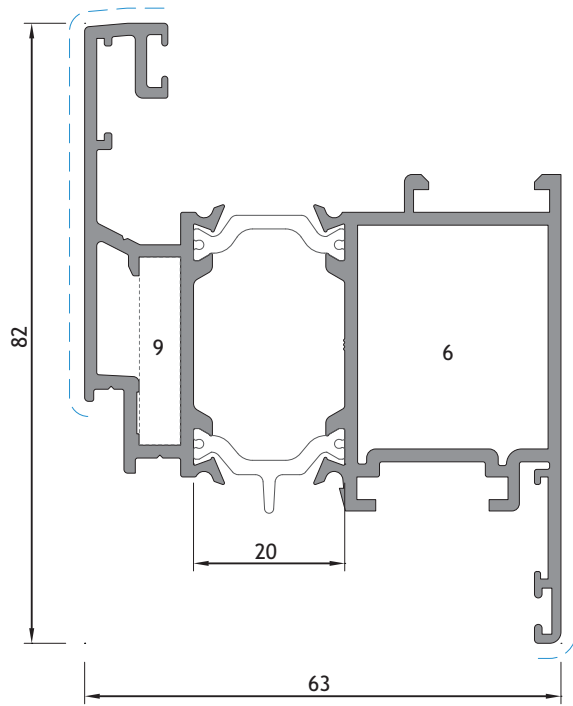

IT 11

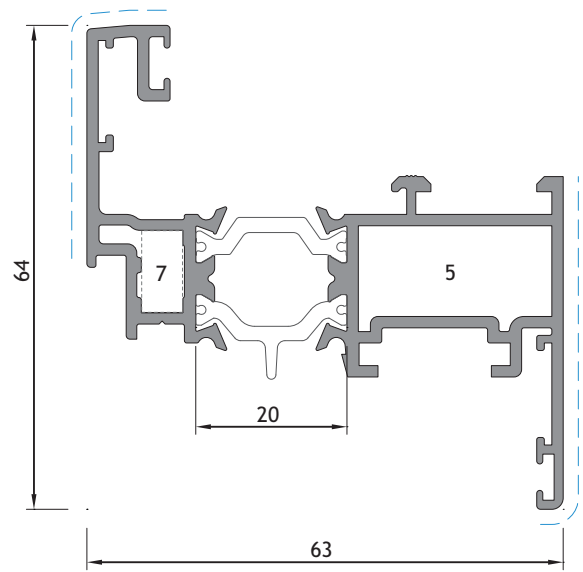

IT 02

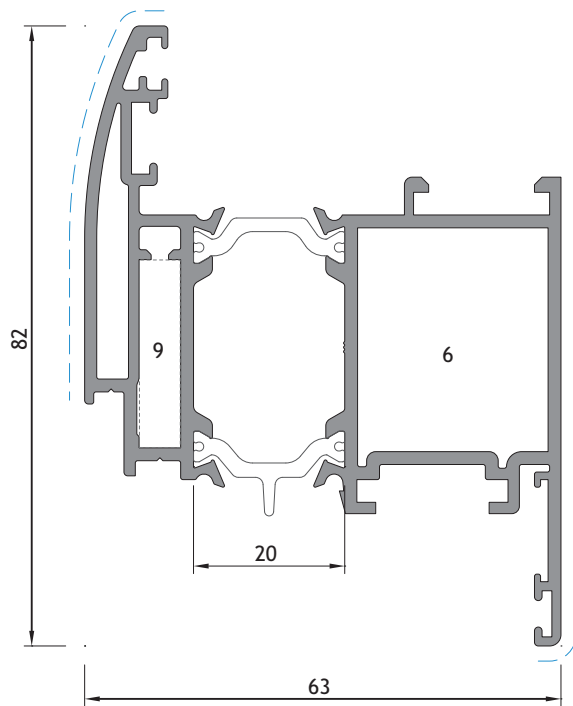

IT 88

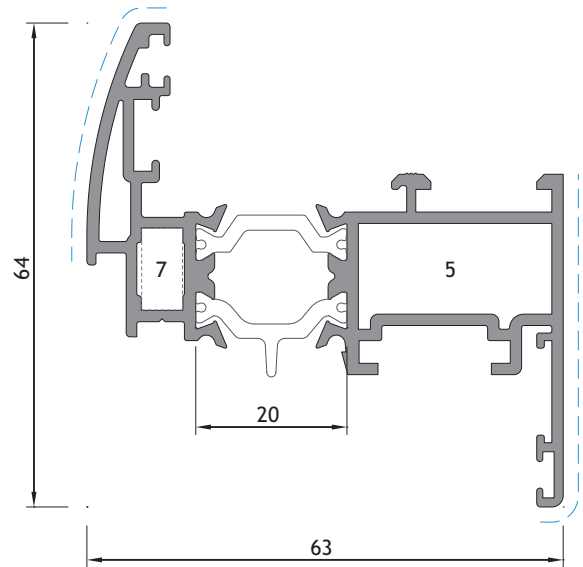

IT 85

1 - ESQUADRO IT/ST Nº 1  
6 - ESQUADRO IT/ST Nº 6  
11 - ESQUADRO AT E. G.

2 - ESQUADRO IT/ST Nº 2  
7 - CANTO CR 0018 + PINOS PEQ.  
12 - ESQUADRO AT E. P.

3 - ESQUADRO IT/ST Nº 3  
8 - ESQUADRO 18-1112-C  
13 - ESQUADRO 18-1414-C

4 - ESQUADRO IT/ST Nº 4  
9 - CANTO CR 0182 + PINOS GR.  
14 - ESQUADRO 1108

5 - ESQUADRO IT/ST Nº 5  
10 - ESQUADRO 18-1130-C  
15 - ESQUADRO 26-2537-140

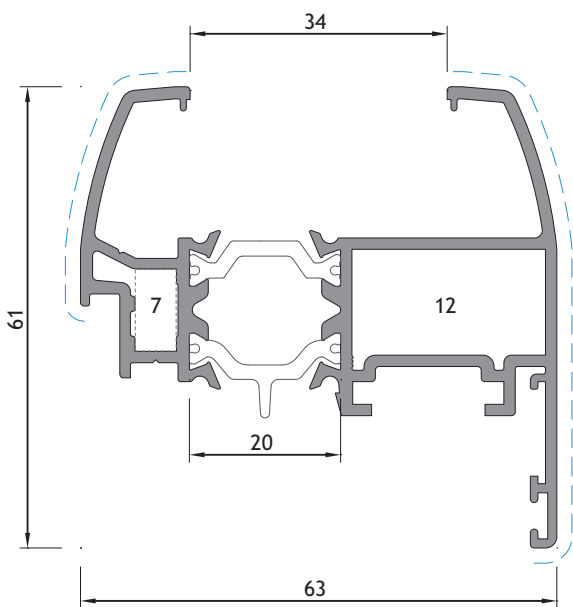

IT 43

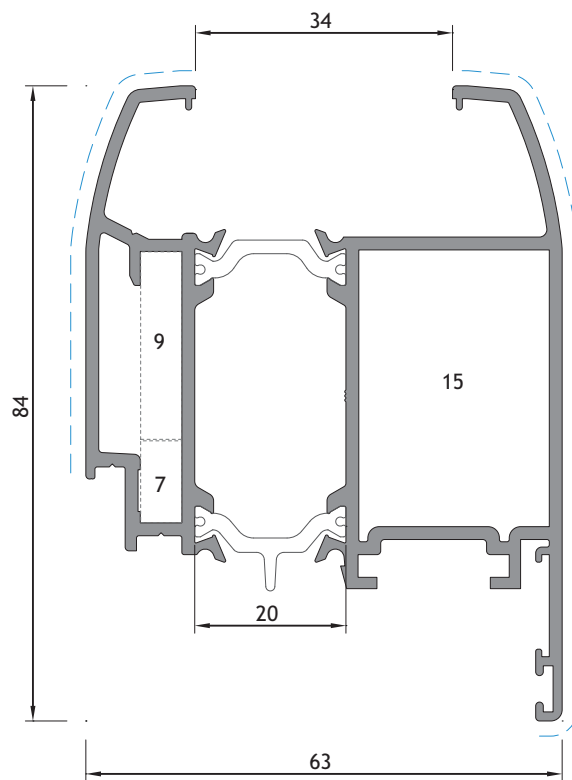

IT 86

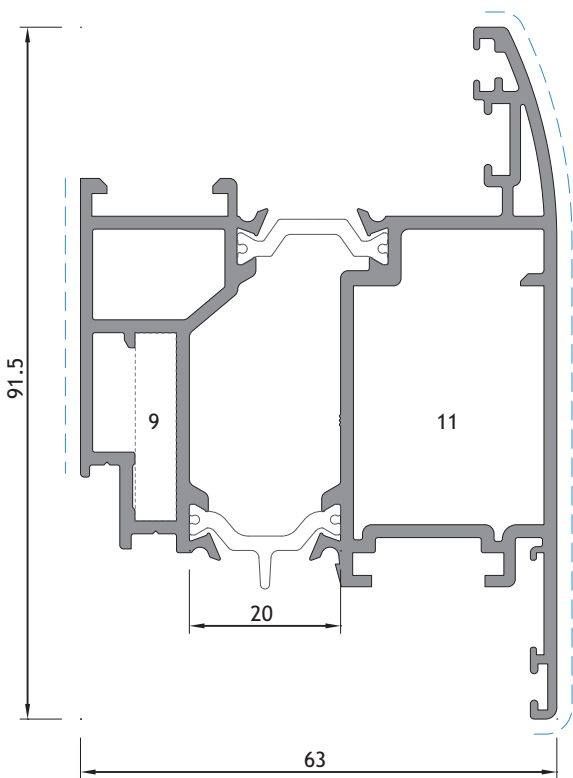

IT 09

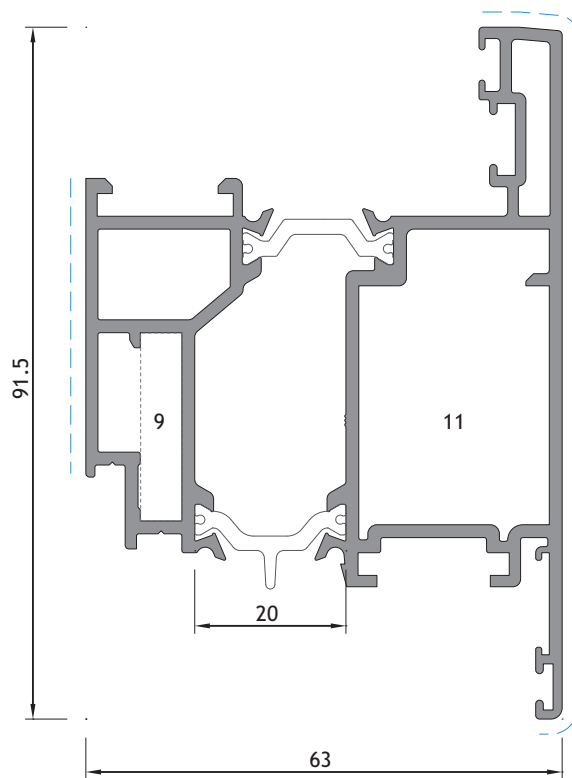

IT 12



1 - ESQUADRO IT/ST Nº 1  
6 - ESQUADRO IT/ST Nº 6  
11 - ESQUADRO AT E. G.

2 - ESQUADRO IT/ST Nº 2  
7 - CANTO CR 0018 + PINOS PEQ.  
12 - ESQUADRO AT E.P.

3 - ESQUADRO IT/ST Nº 3  
8 - ESQUADRO 18-1112-C  
13 - ESQUADRO 18-1414-C

4 - ESQUADRO IT/ST Nº 4  
9 - CANTO CR 0182 + PINOS GR.  
14 - ESQUADRO 1108

5 - ESQUADRO IT/ST Nº 5  
10 - ESQUADRO 18-1130-C  
15 - ESQUADRO 26-2537-140

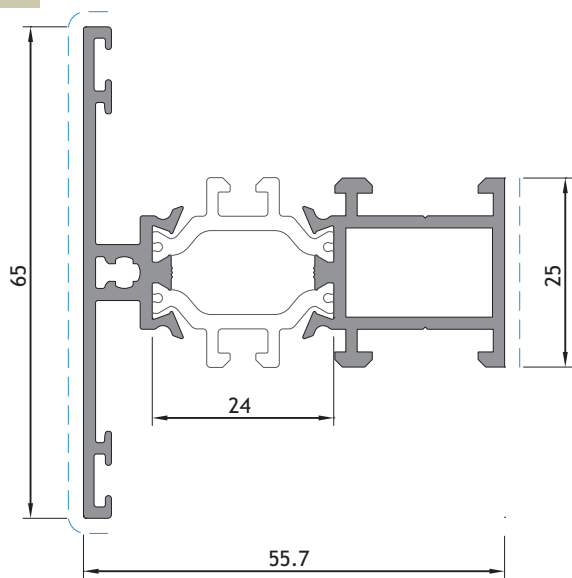

IT 20

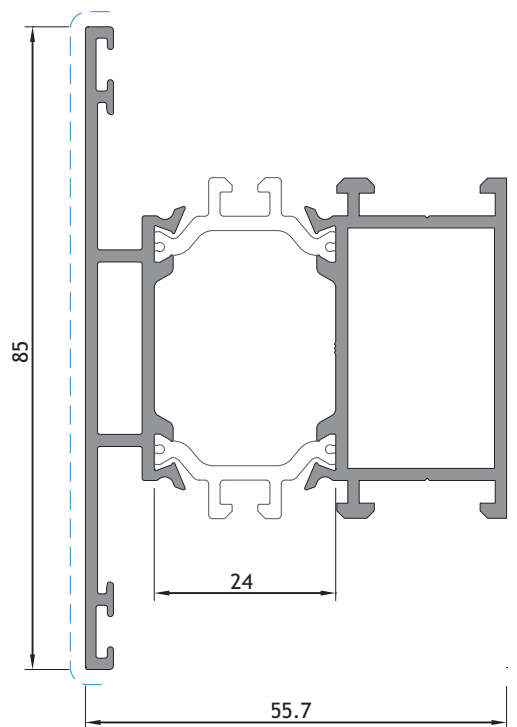

IT 36

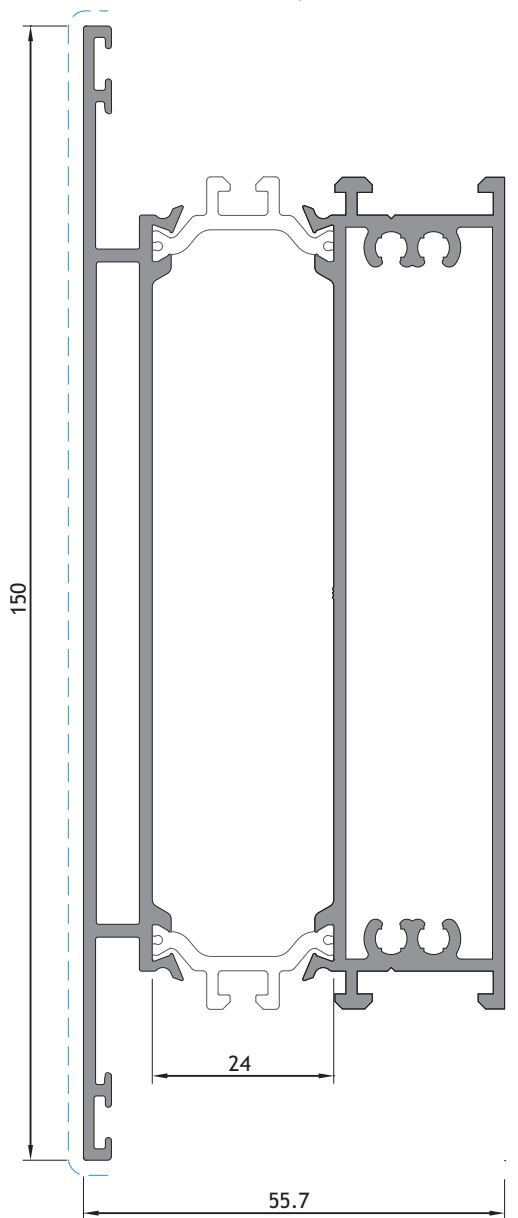

IT 14

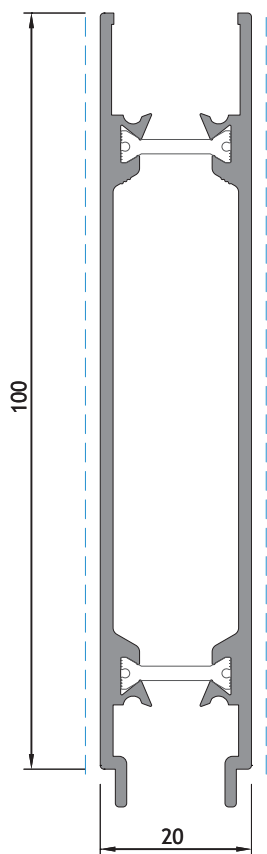

AT 16

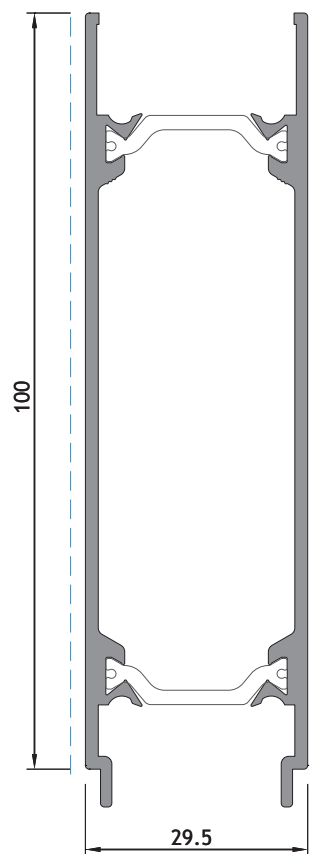

LT 16

- 1 - ESQUADRO IT/ST Nº 1
- 6 - ESQUADRO IT/ST Nº 6
- 11 - ESQUADRO AT E. G.

- 2 - ESQUADRO IT/ST Nº 2
- 7 - CANTO CR 0018 + PINOS PEQ.
- 12 - ESQUADRO AT E.P.

- 3 - ESQUADRO IT/ST Nº 3
- 8 - ESQUADRO 18-1112-C
- 13 - ESQUADRO 18-1414-C

- 4 - ESQUADRO IT/ST Nº 4
- 9 - CANTO CR 0182 + PINOS GR.
- 14 - ESQUADRO 1108

- 5 - ESQUADRO IT/ST Nº 5
- 10 - ESQUADRO 18-1130-C
- 15 - ESQUADRO 26-2537-140



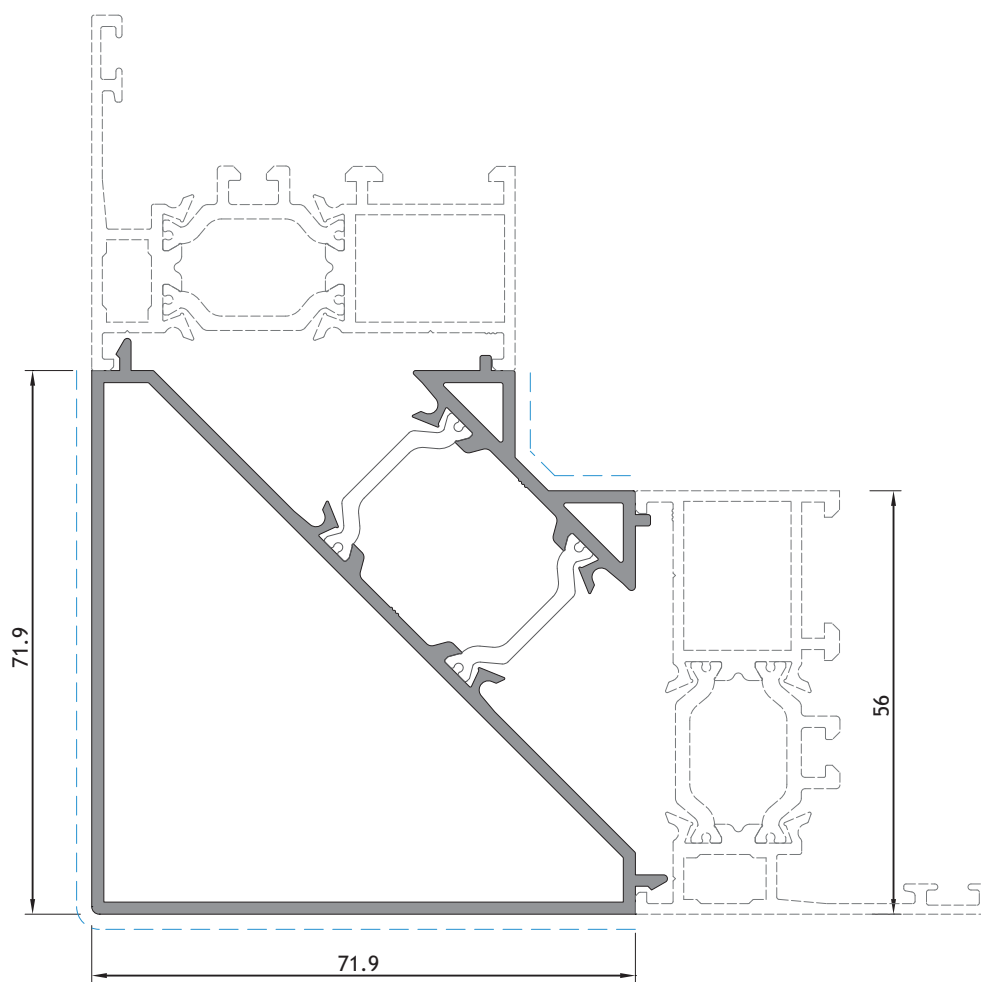

IS 55

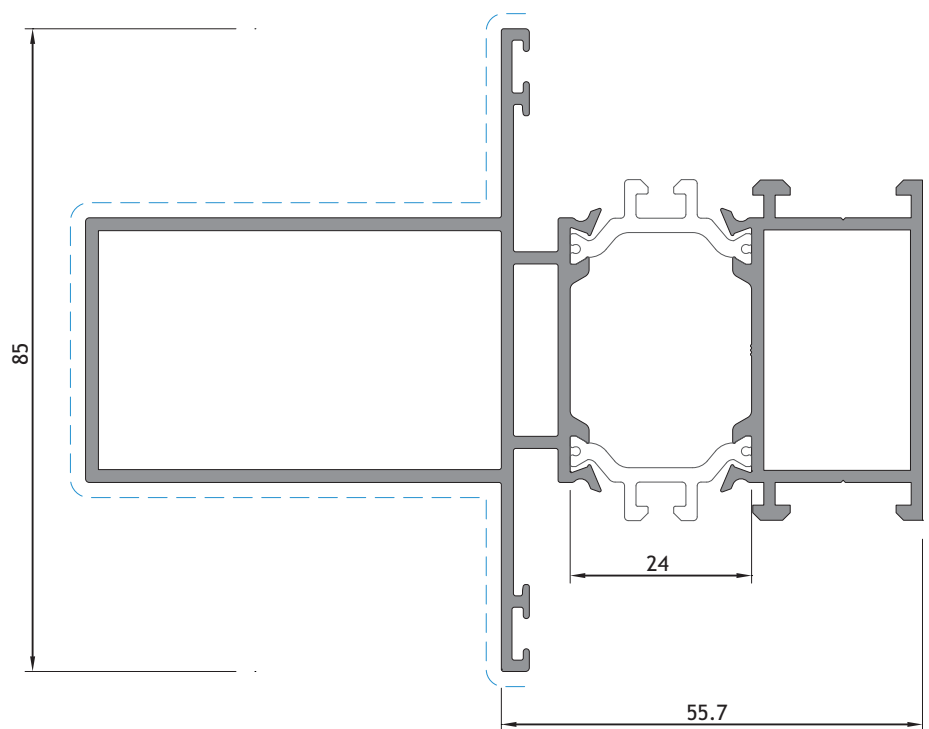

IT 19



1 - ESQUADRO IT/ST Nº 1  
6 - ESQUADRO IT/ST Nº 6  
11 - ESQUADRO AT E. G.

2 - ESQUADRO IT/ST Nº 2  
7 - CANTO CR 0018 + PINOS PEQ.  
12 - ESQUADRO AT E.P.

3 - ESQUADRO IT/ST Nº 3  
8 - ESQUADRO 18-1112-C  
13 - ESQUADRO 18-1414-C

4 - ESQUADRO IT/ST Nº 4  
9 - CANTO CR 0182 + PINOS GR.  
14 - ESQUADRO 1108

5 - ESQUADRO IT/ST Nº 5  
10 - ESQUADRO 18-1130-C  
15 - ESQUADRO 26-2537-140

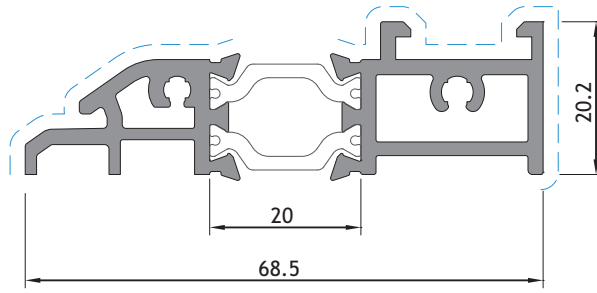

IT 49

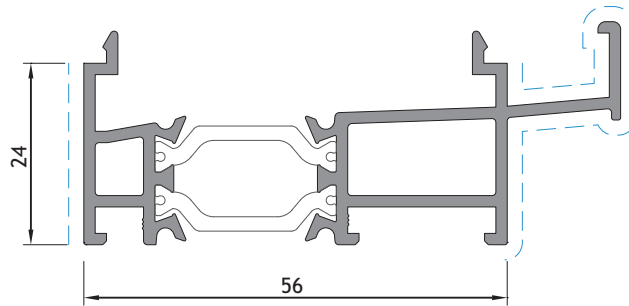

IT 27

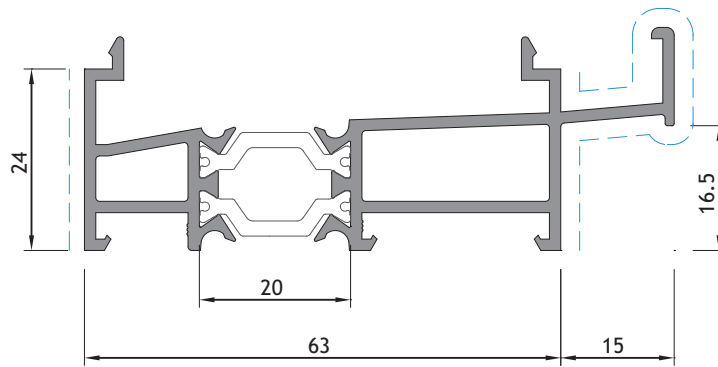

IT 76

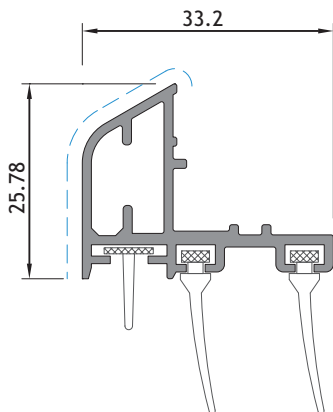

IT 32

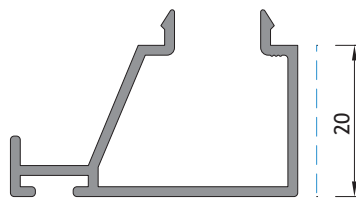

AT 59

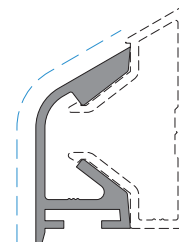

SA 32

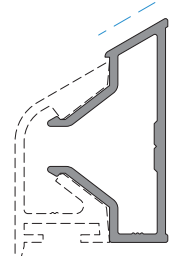

SA 31

1 - ESQUADRO IT/ST Nº 1  
6 - ESQUADRO IT/ST Nº 6  
11 - ESQUADRO AT E. G.

2 - ESQUADRO IT/ST Nº 2  
7 - CANTO CR 0018 + PINOS PEQ.  
12 - ESQUADRO AT E.P.

3 - ESQUADRO IT/ST Nº 3  
8 - ESQUADRO 18-1112-C  
13 - ESQUADRO 18-1414-C

4 - ESQUADRO IT/ST Nº 4  
9 - CANTO CR 0182 + PINOS GR.  
14 - ESQUADRO 1108

5 - ESQUADRO IT/ST Nº 5  
10 - ESQUADRO 18-1130-C  
15 - ESQUADRO 26-2537-140

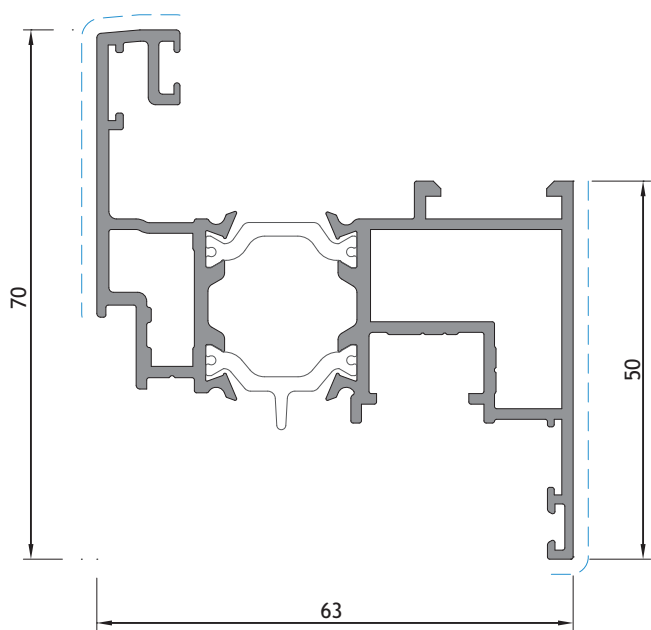

IT 04

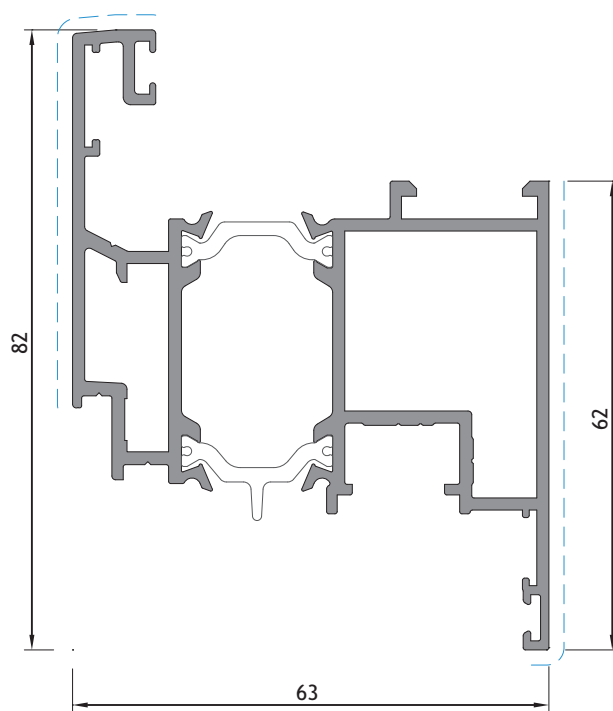

IT 05

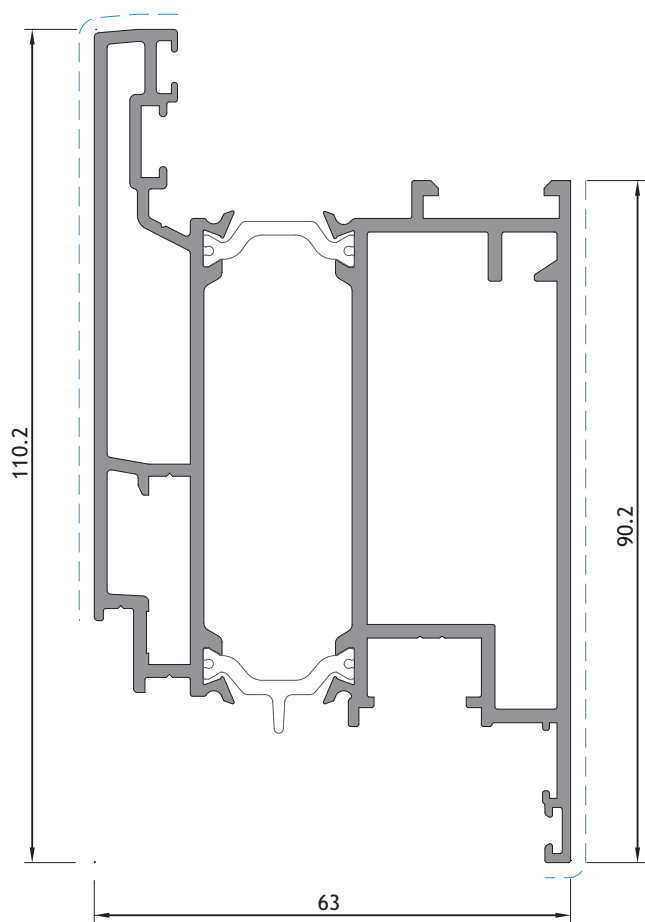

IT 66

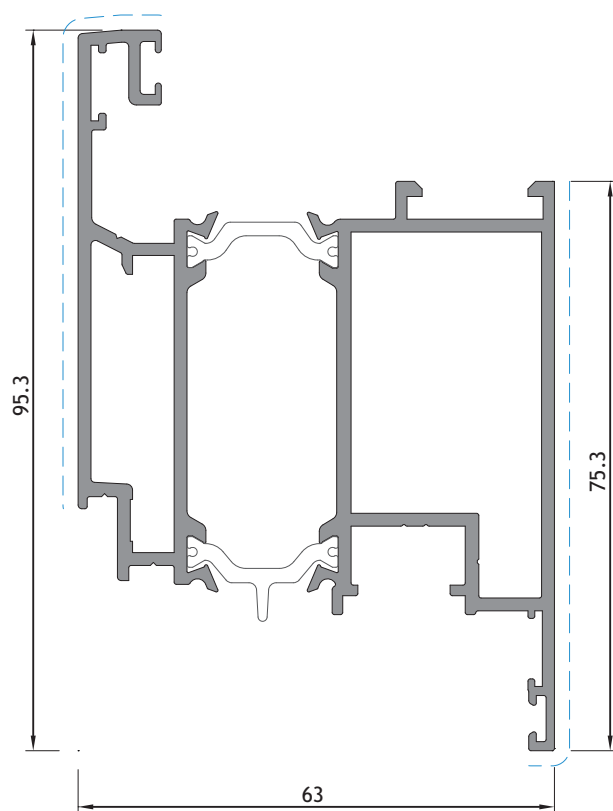

IT 48

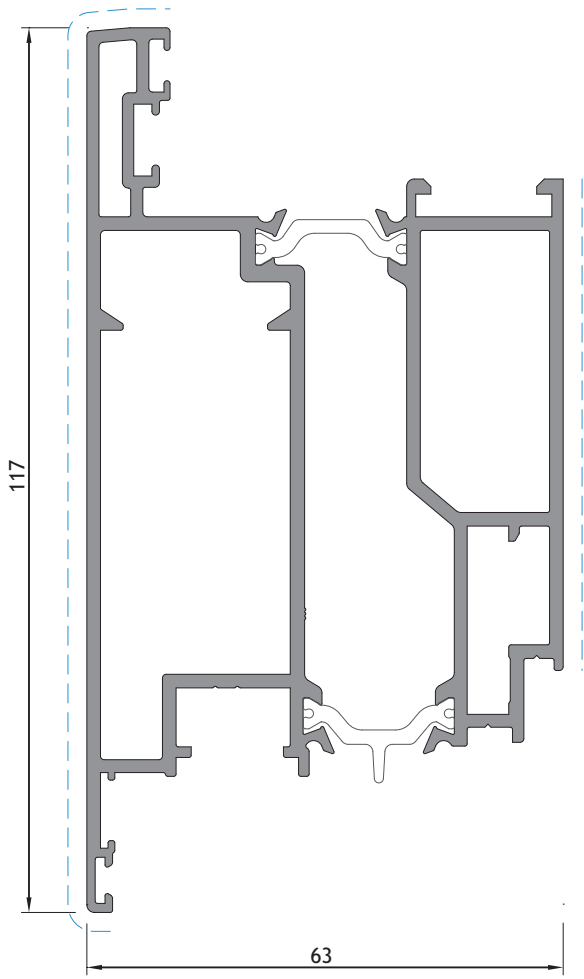

IT 23

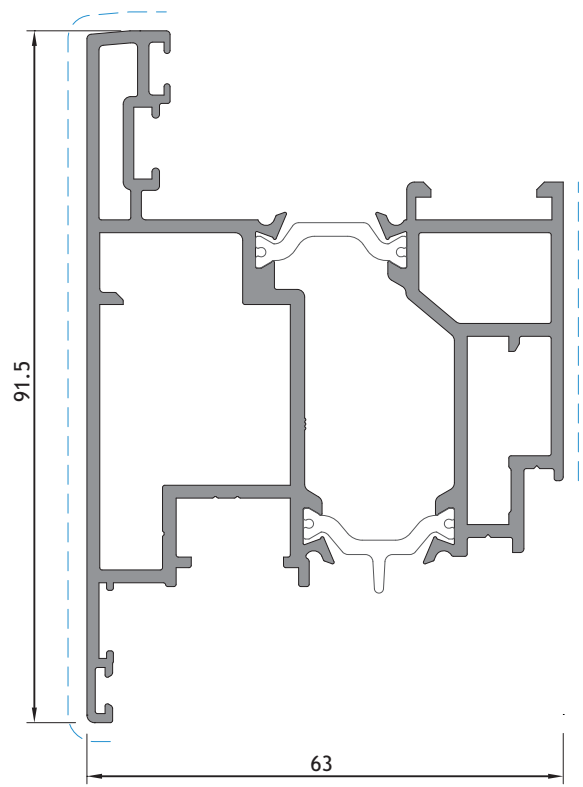

IT 13

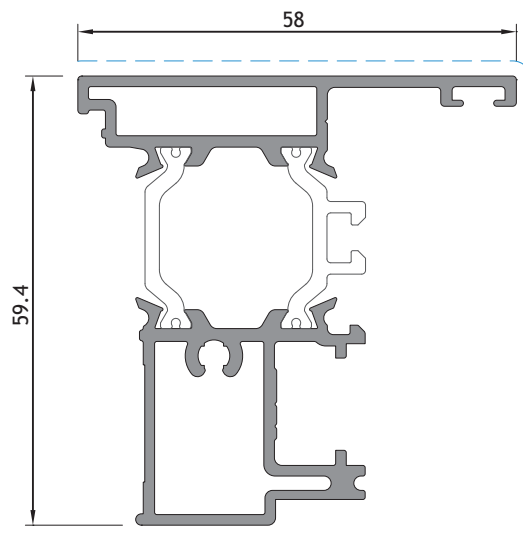

IT 76



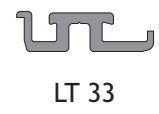
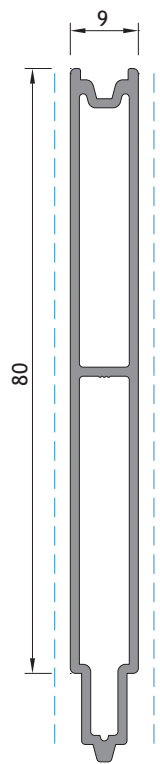
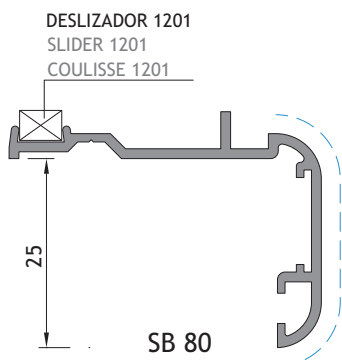

LT 33

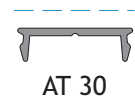

AT 30

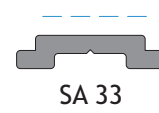

SA 33

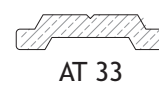

AT 33

PERFIL EM POLIAMIDA - NÃO UTILIZAR EM FERRAGENS OSCILO-BATENTE E/OU OSCILO-PARALELA  
 PROFILE IN POLYAMIDE - DO NOT USE IN TILT-AND-TURN AND/OR TILT-AND-SLIDE HARDWARE  
 PROFIL EN POLYAMIDE - NE PAS UTILISER DANS LES ACCESSOIRES OSCILLO-BATTANT ET/OU OSCILLO-COULISSANT

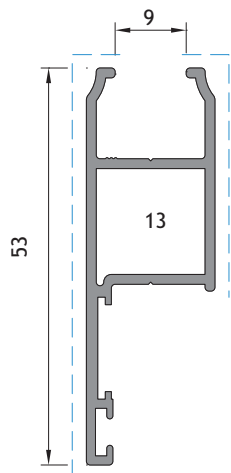

SB 63

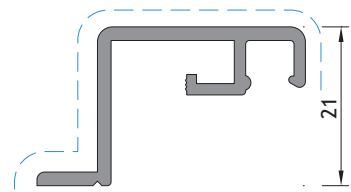

PB 32

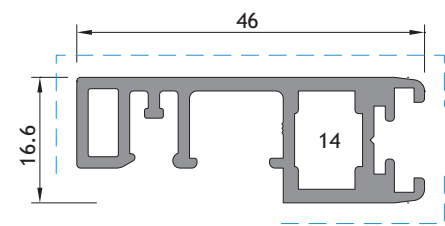

KY 86

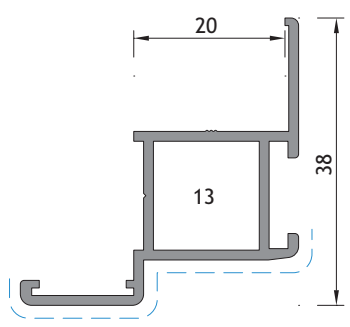

KY 69

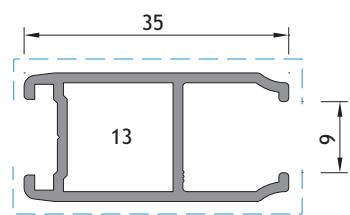

KY 70

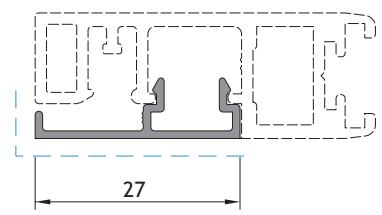

KY 87

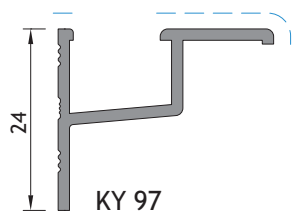

KY 97

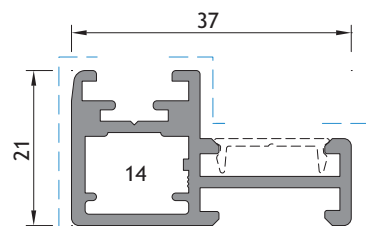

KY 84

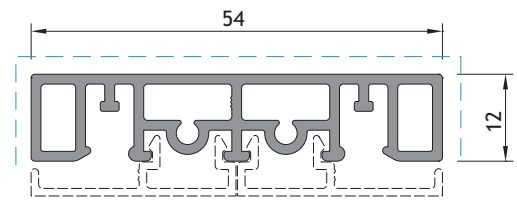

KY 89



- 1 - ESQUADRO IT/ST Nº 1
- 2 - ESQUADRO IT/ST Nº 2
- 3 - ESQUADRO IT/ST Nº 3
- 4 - ESQUADRO IT/ST Nº 4
- 5 - ESQUADRO IT/ST Nº 5
- 6 - ESQUADRO IT/ST Nº 6
- 7 - CANTO CR 0018 + PINOS PEQ.
- 8 - ESQUADRO 18-1112-C
- 9 - CANTO CR 0182 + PINOS GR.
- 10 - ESQUADRO 18-1130-C
- 11 - ESQUADRO AT E. G.
- 12 - ESQUADRO AT E.P.
- 13 - ESQUADRO 18-1414-C
- 14 - ESQUADRO 1108
- 15 - ESQUADRO 26-2537-140

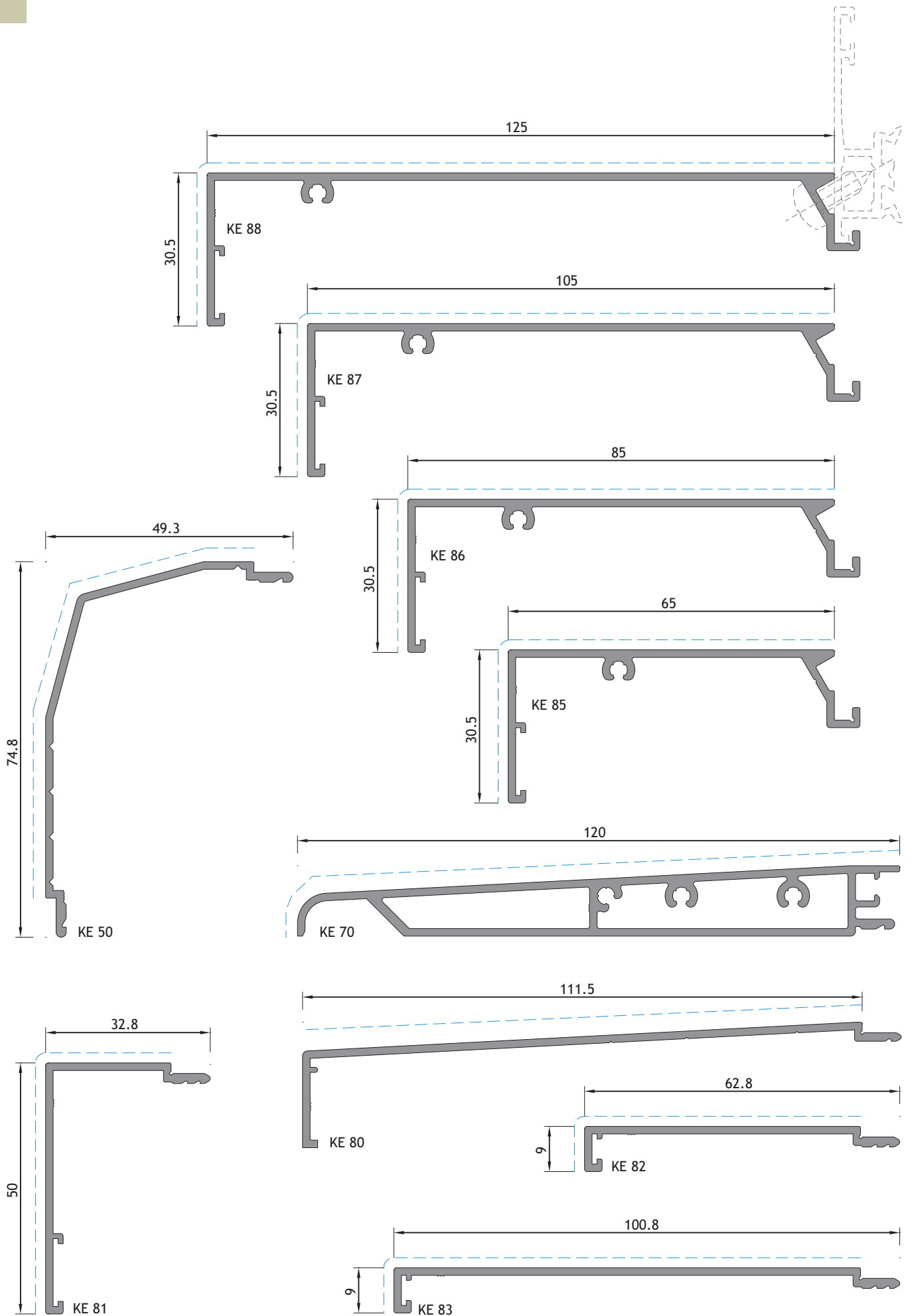



TABELA DE BITES | GLAZING BEADS | PARCLOSSES



**MOLA EURO 2000** Ref: 228165  
 Para aplicar com os bites com referência SA Lacados  
 To apply with the glazing beads with reference SA Powder coated  
 Pour appliquer avec les parcloses avec référence SA laqué

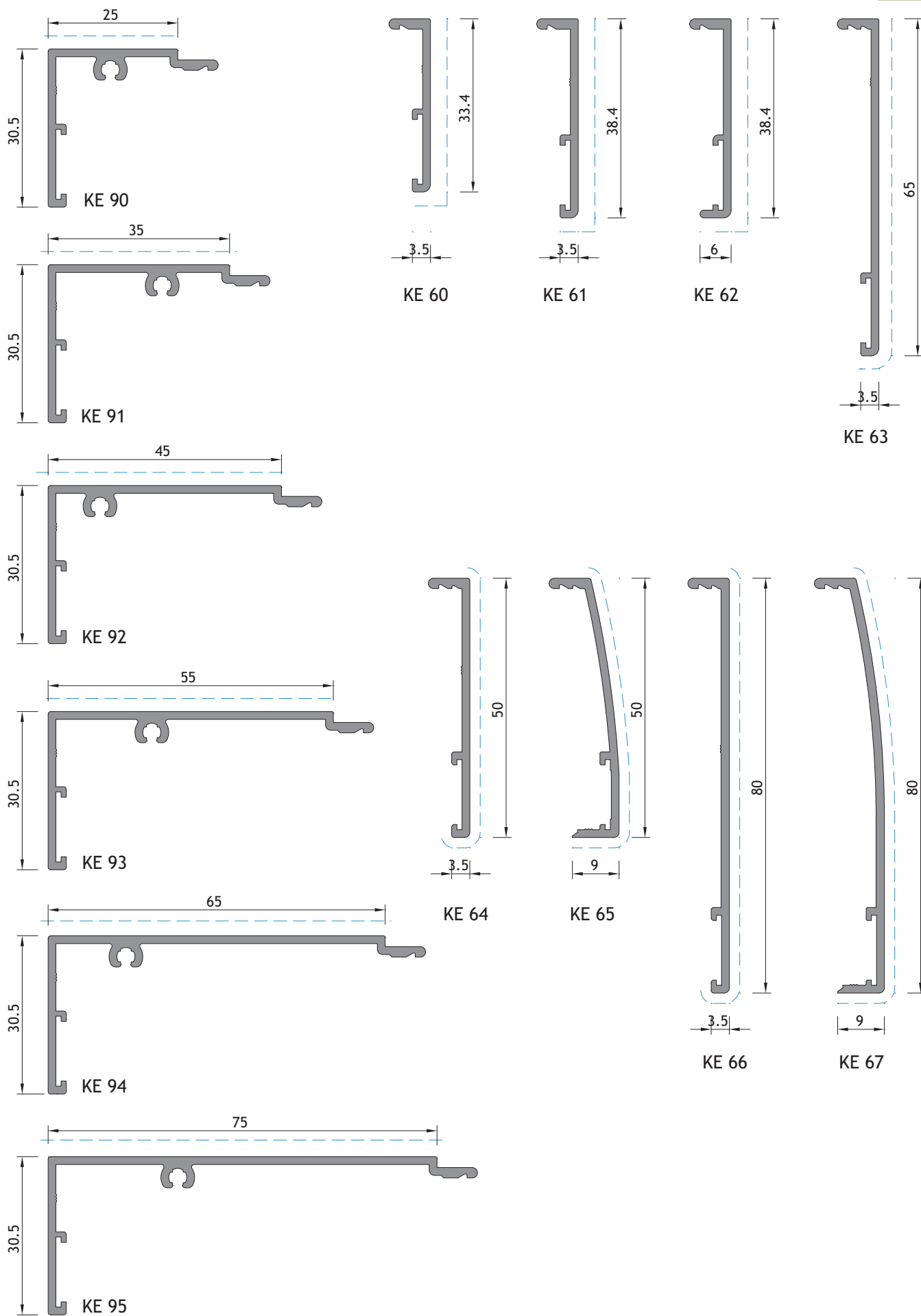
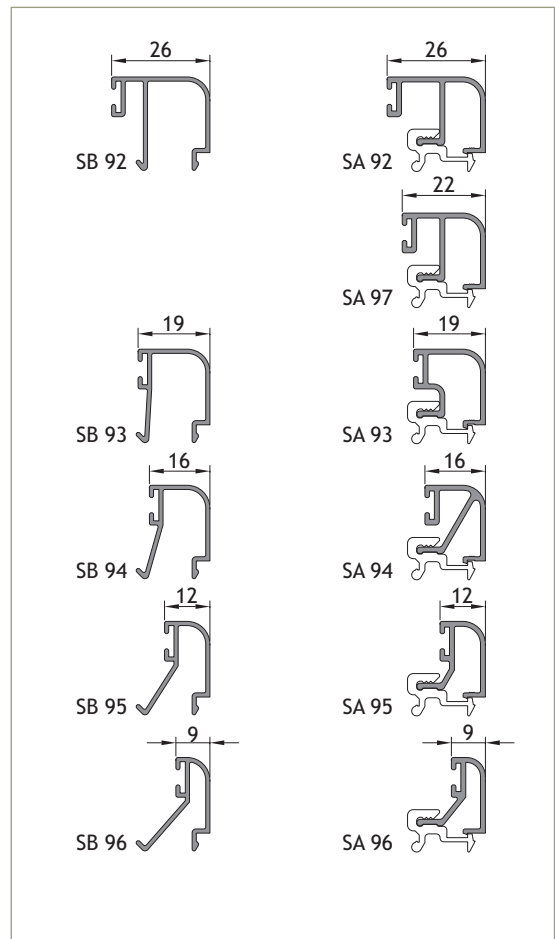
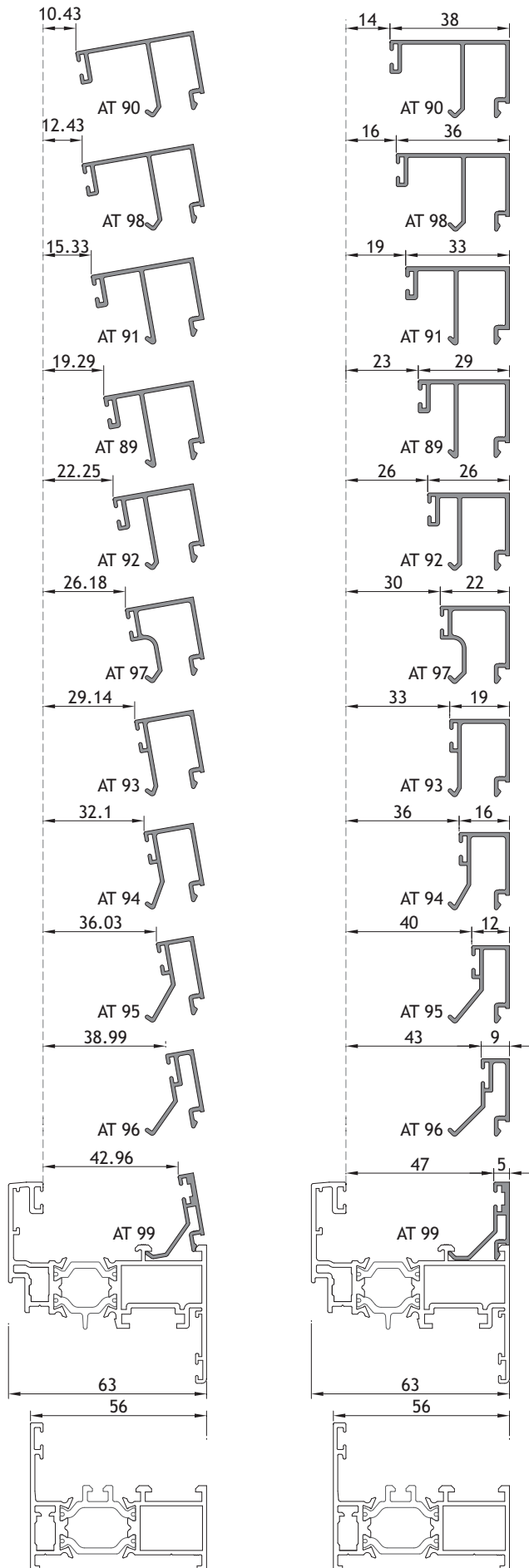

**PRESILHA SA 71 EM ALUMÍNIO** Ref: 207202  
 Para aplicar com os bites com referência SA  
 To apply with the glazing beads with reference SA  
 Pour appliquer avec les parcloses avec référence SA









## **Acessórios**

Accessories

Accessoires







**2001**  
Material: EPDM  
(Caixa: 8 rolosx50m)

**2051**  
Material com 2 durezas  
(Zona de batente: E.P.D.M. esponjoso)  
(Base: E.P.D.M. de 70° SHORE)  
(Rolo: 300m (150m+150m))

**2071**  
Material: EPDM, 2 durezas  
(Caixa: 300m)

208274 JUNTA DE ESTANQUIDADE 2001  
208008 JUNTA DE ESTANQUIDADE 2051  
208143 JUNTA DE ESTANQUIDADE 2071

**2305**  
Material: EPDM  
(Barras: 6,3m)

**2105**  
Material: EPDM  
(Caixa: 150m)

208486 JUNTA DE VEDAÇÃO CENTRAL 2105.N  
208144 JUNTA DE VEDAÇÃO CENTRAL 2305

**2042** **2073** **2034** **2035** **2037**

Material: EPDM  
Rolo: 200m

208191 JUNTA DE CUNHA 2042  
208195 JUNTA DE CUNHA 2034

208196 JUNTA DE CUNHA 2035  
208904 JUNTA DE CUNHA 2037  
208199 JUNTA DE CUNHA 2073

213290 CANTO VULCANIZADO 2105.1N

**2003**  
Material: EPDM  
Rolo: 100m

**2055**  
Material: EPDM  
Rolo: 200m

208350 JUNTA DE VEDAÇÃO EXTERIOR 2003  
208289 JUNTA DE BATENTE 2055

8.5  
12

Para os perfis SA32 ou IT 32  
(Rolo: 300m)

208464 JUNTA PELÚCIA 8.5x12 S-FIN

**2112**  
(Material: EPDM)  
(Rolo: 200m)

**2412**  
(Material: EPDM)  
(Rolo: 200m)

Apliação facultativa

208278 JUNTA DE ESTANQUIDADE 2112  
208184 JUNTA DE ESTANQUIDADE 2412

17.5  
23  
10.8

**VR3105** **VR3180** **5007**

VR 3105 = Junta de 2 durezas em PVC para o perfil SB 32  
VR 3180 = Junta de 2 durezas em PVC para o perfil SB 32  
- Alternativa à Junta VR3105 no exterior  
5007 = Junta de 2 durezas em PVC para o perfil SB 49

208292 JUNTA INFERIOR PORTA VR3105  
208294 JUNTA INFERIOR PORTA VR3180  
208165 JUNTA INFERIOR PORTA 5007 PRETO

Material: EPDM  
(Caixa: 50m)

208145 JUNTA DE REMATE PAREDE 2079

Para o perfil LT 32  
(Rolo: 100m)

208246 JUNTA ENCAIXE 1140 PRT

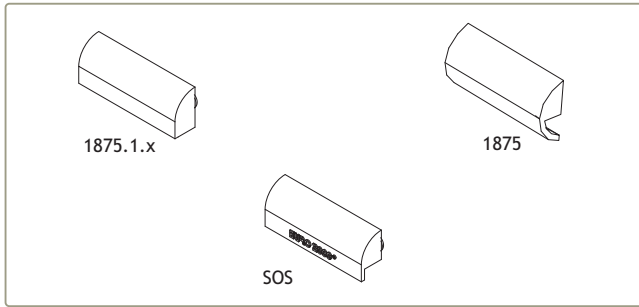

210154 GOTEIRA 1875 Br/Pr      210142 GOT. C/VÁLV. 1875.1.75  
 210280 GOTEIRA SOS C/ VÁLV. Br/Pr.      210144 GOT. C/VÁLV. 1875.1.78

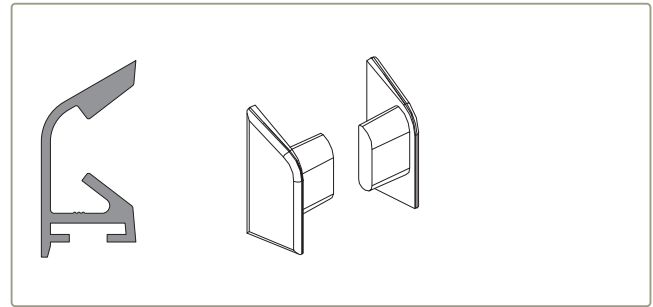

212346 CONJ. TAPA-TOPOS SA 32 Br/Pr

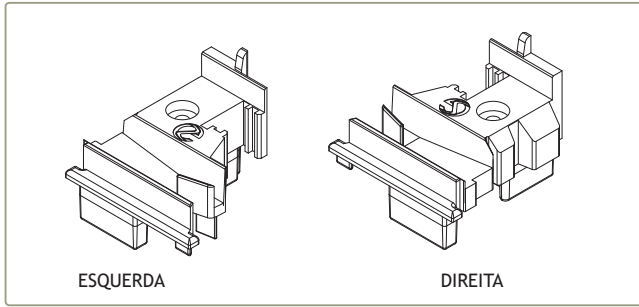

212063 CONJUNTO TOPO INVERSOR IT Preto

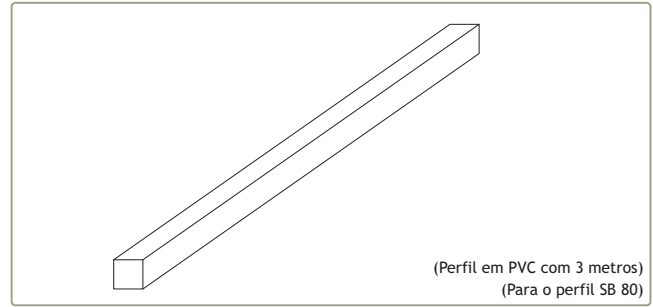

219133 DESLIZADOR DE CALHA 1201  
 (Perfil em PVC com 3 metros)  
 (Para o perfil SB 80)

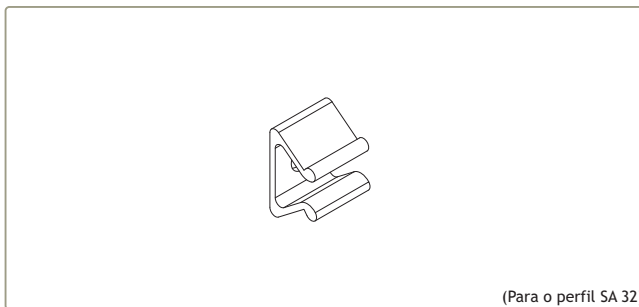

228181 MOLA PARA PINGADEIRA  
 (Para o perfil SA 32)

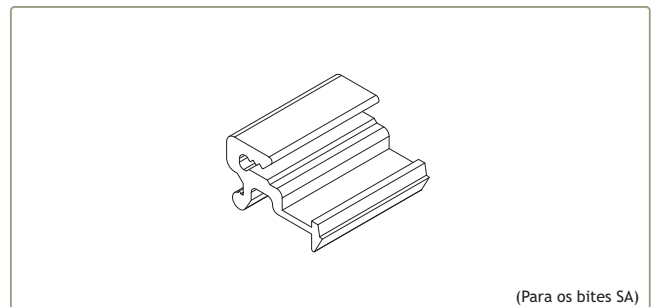

228165 MOLA EURO 2000  
 (Para os bites SA)

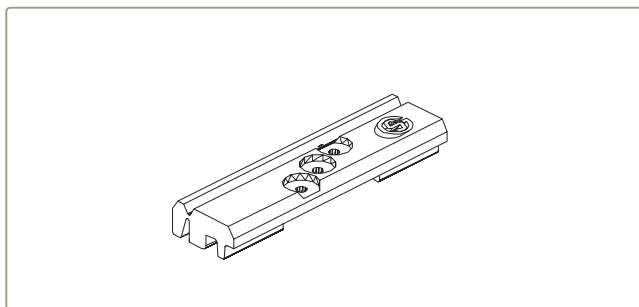

218194 CALÇO P/VIDRO EURO 2000 Nylon

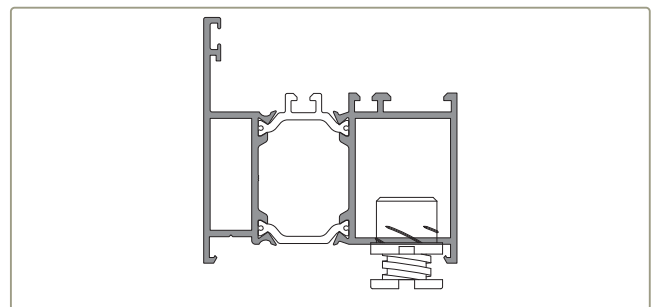

224205 NIVELADOR PEQUENO 600.01/8

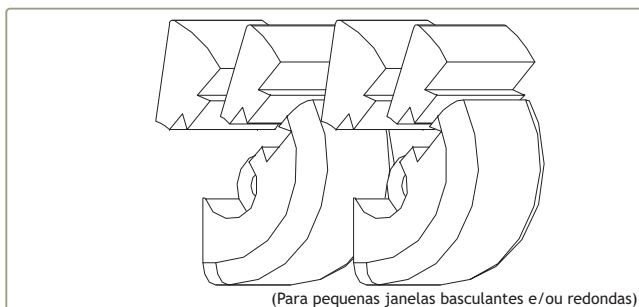

212146 CONJUNTO PARA BASCULANTE B215 Pr.  
 212148 CONJUNTO PARA BASCULANTE B217 Br.

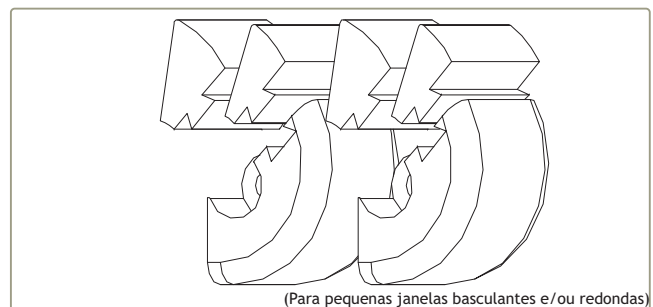

212150 CONJUNTO PARA BASCULANTE B218 Pr.  
 212152 CONJUNTO PARA BASCULANTE B220 Br.

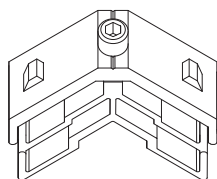

Para os perfis IT 01, 31, 38, 61 e 81

204137

ESQUADRO IT/ST Nº1 16-1914-C

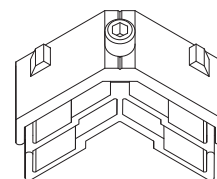

Para os perfis IT 28, 41 e 51

204138

ESQUADRO IT/ST Nº2 16-1914-D

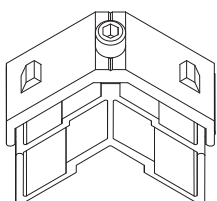

Para os perfis IT 07, 56 e 67

204139

ESQUADRO IT/ST Nº3 16-1931-C

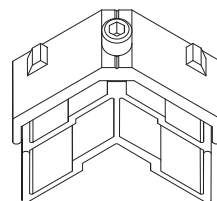

Para os perfis IT 47, 57 e 69

204141

ESQUADRO IT/ST Nº4 16-1931-D

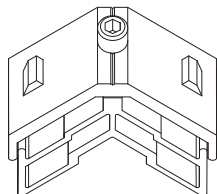

Para os perfis IT 02 e 85

204142

ESQUADRO IT/ST Nº5 18-2512-140

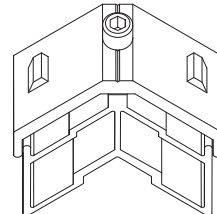

Para os perfis IT 11 e 88

204143

ESQUADRO IT/ST Nº6 18-2530-140

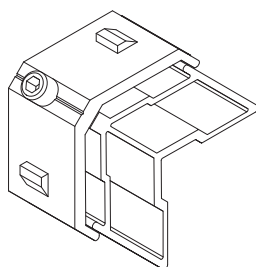

Para os perfis IT 09 e 12

204730

ESQUADRO AT E. GRANDE

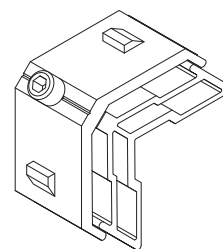

Para o perfil IT 43

204728

ESQUADRO AT E. PEQUENO

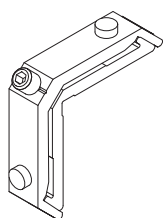

Para o perfil IT 38

204901

ESQUADRO 18-1112-C

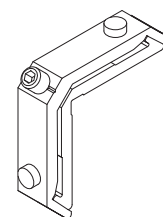

(Para os perfis IT 83, SB 63, KY 69 e KY 70)

204029

ESQUADRO 18-1414 C

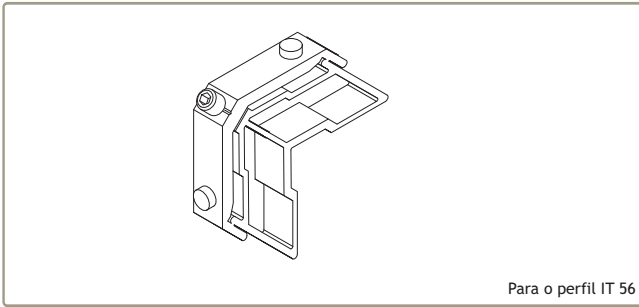

Para o perfil IT 56

204009

ESQUADRO 18-1130-C

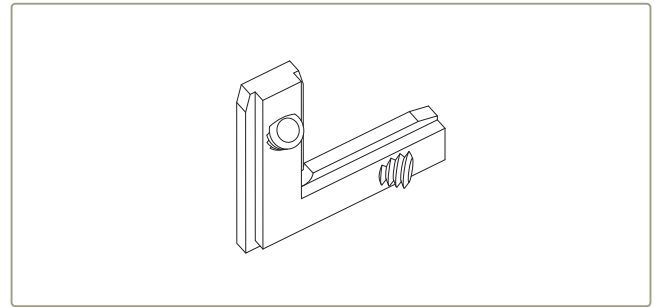

204131

ESQUADRO DE ALINHAMENTO C/ APERTO

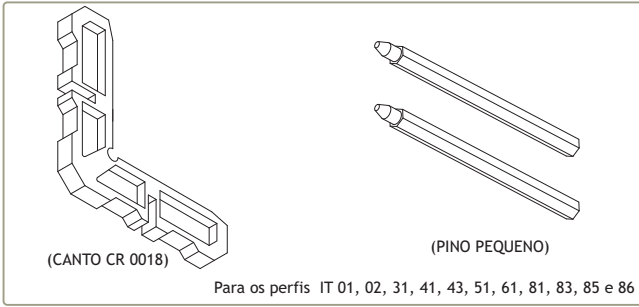

(CANTO CR 0018)

(PINO PEQUENO)

Para os perfis IT 01, 02, 31, 41, 43, 51, 61, 81, 83, 85 e 86

213259

CANTO CR 0018 + PINOS PEQ.

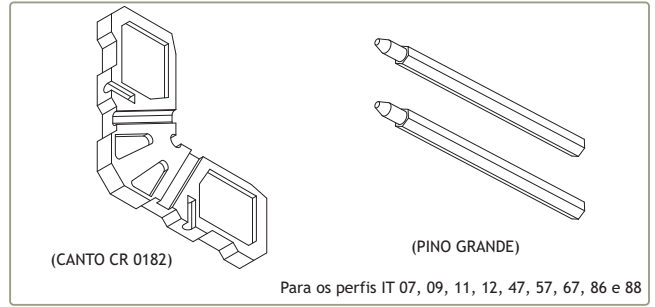

(CANTO CR 0182)

(PINO GRANDE)

Para os perfis IT 07, 09, 11, 12, 47, 57, 67, 86 e 88

213247

CANTO CR 0182 + PINOS GR.

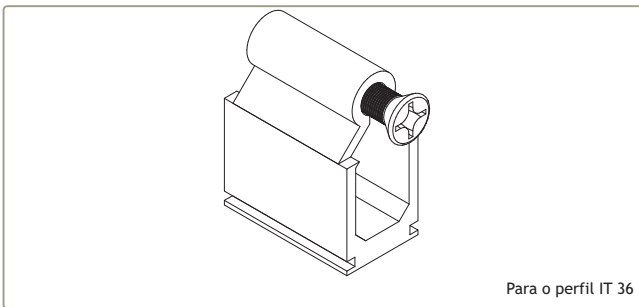

Para o perfil IT 36

232116  
290037

UNIÃO TRAVESSAS SA2001 G  
PARAFUSO SUPLEMENTAR P/UNIÃO SA2001 G INOX

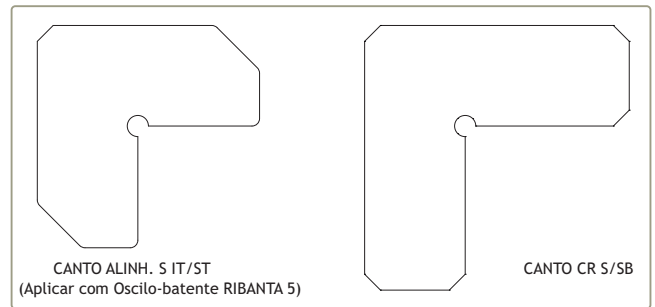

CANTO ALINH. S IT/ST  
(Aplicar com Oscilo-batente RIBANTA 5)

CANTO CR S/SB

213261  
213246

CANTO ALINH. S IT/ST  
CANTO CR S/SB

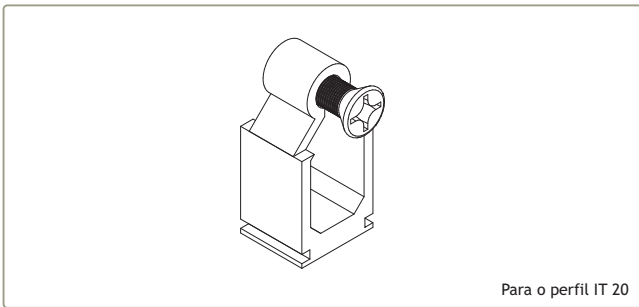

Para o perfil IT 20

232119

UNIÃO TRAVESSAS SA2001 XP

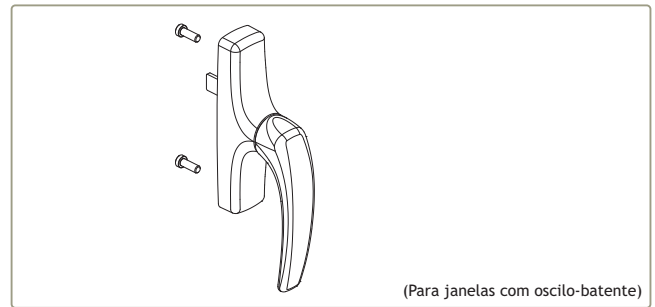

(Para janelas com oscilo-batente)

000000

CREMONE ARIANA 868.2

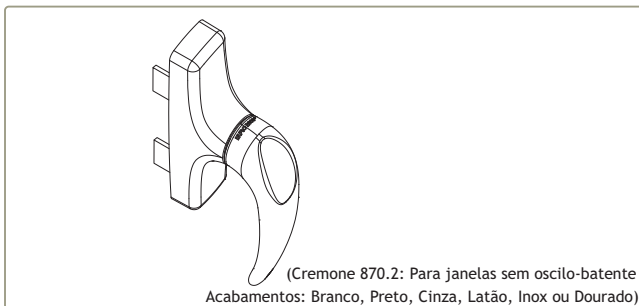

(Cremone 870.2: Para janelas sem oscilo-batente  
Acabamentos: Branco, Preto, Cinza, Latão, Inox ou Dourado)

200302

CREMONE MANON 870.2

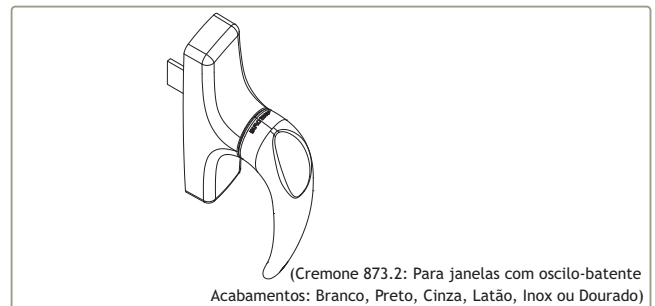

(Cremone 873.2: Para janelas com oscilo-batente  
Acabamentos: Branco, Preto, Cinza, Latão, Inox ou Dourado)

200315

CREMONE MANON 873

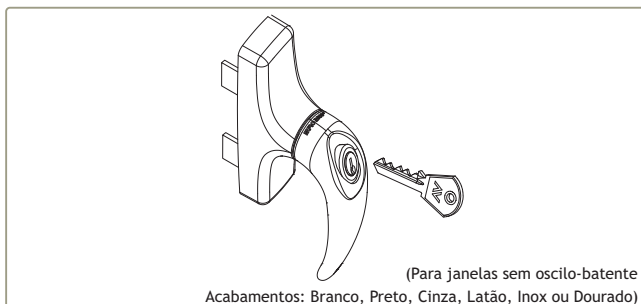

200215

CREMONE MANON 870.754

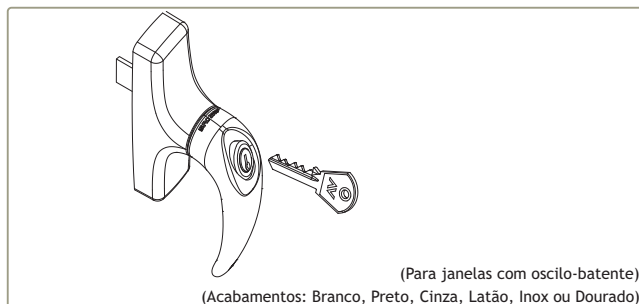

200969

CREMONE MANON 873.754

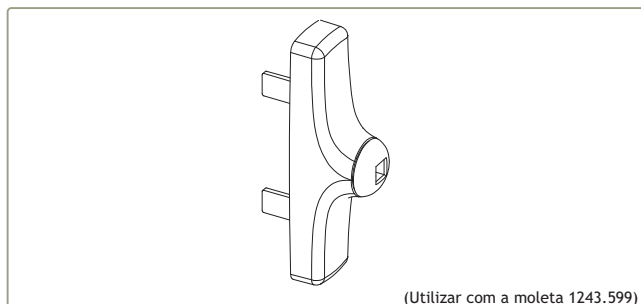

200405

CREMONE SEM MOLETA 870.752 Preto

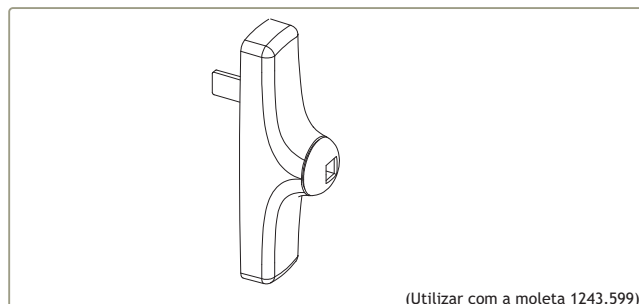

200406

CREMONE P/OSCILO-BATENTE S/MOLETA 873.756 Preto

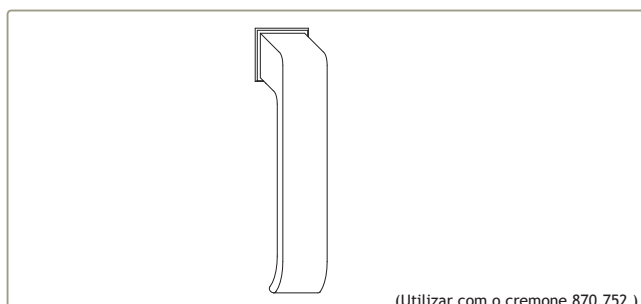

211310

MOLETA CREM. 1243.599 Preto



215114

PEÇA CREMONE VARETA 1481



206490

TERMINAL VARETA 1486

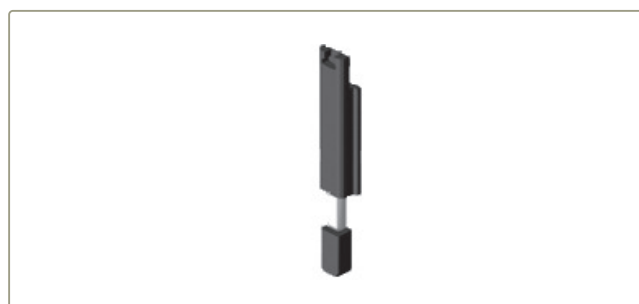

206500

TERMINAL VARETA 2000



206475

TERMINAL VARETA C/ REGULAÇÃO 1487



202090

CONTRA-FECHO DUPLO 1416.6



202077

CONTRA-FECHO 1404

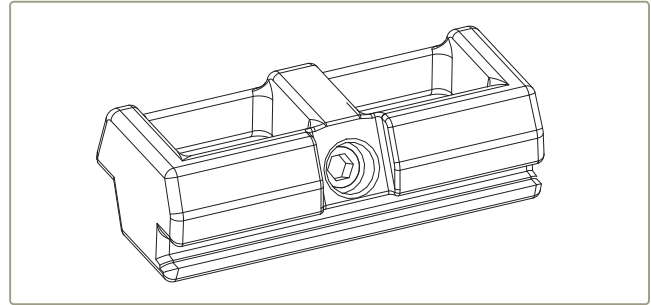

202091

CONTRA-FECHO DUPLO REGULÁVEL 1414

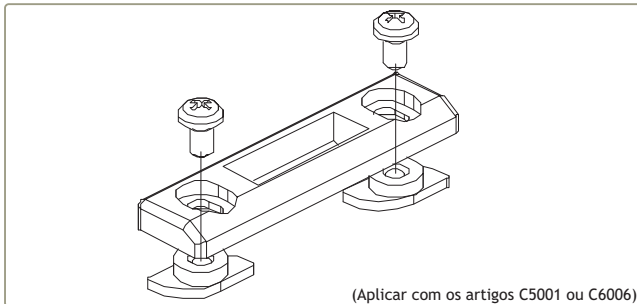

202310

CONTRA-FECHO DUPLO REGULÁVEL 2020

(Aplicar com os artigos C5001 ou C6006)

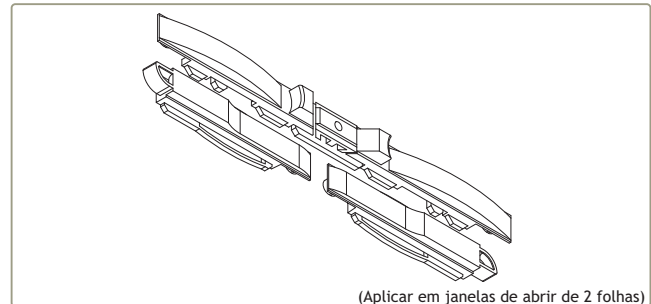

201507

FECHO SEMI-AUTO PARA 2ª FOLHA C5001

(Aplicar em janelas de abrir de 2 folhas)

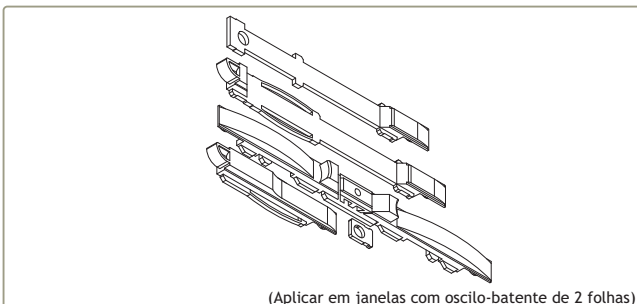

201030

FECHO SEMI-AUTO PARA 2ª F C/O-B C6006

(Aplicar em janelas com oscilo-batente de 2 folhas)

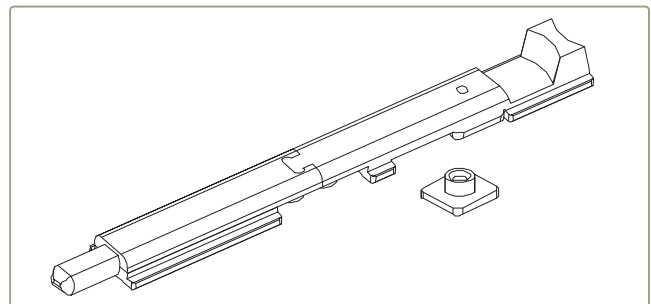

201490

FECHO PARA 2ª FOLHA 1541

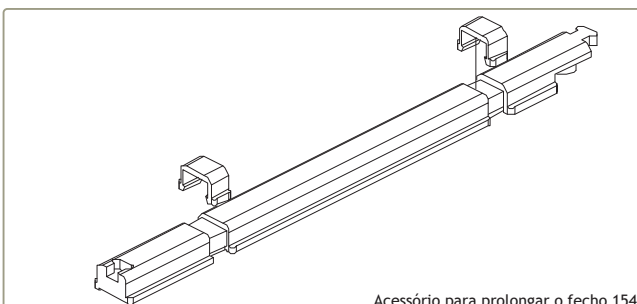

401001

ALONGAMENTO 1541.800

Acessório para prolongar o fecho 1541



214280

VARETA 1541.820

(Aplicar com o fecho 1541 em vãos de 3 ou 4 folhas ou com oscilo-batente)



225130

PASSADOR 3000.854

(Aplicar em janelas de 2 ou 3 folhas com oscilo-batente)

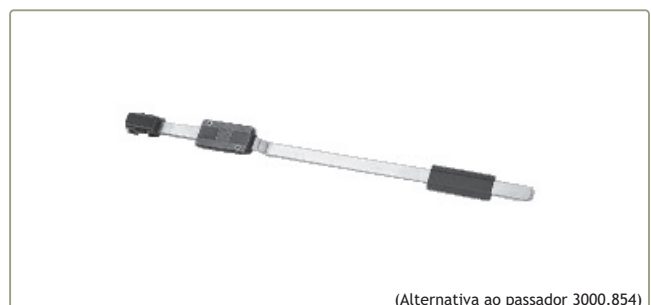

225205

FECHO PARA 2ª FOLHA 1545.2

(Alternativa ao passador 3000.854)



(Para portas de 2, 3 ou 4 folhas)

225155

PASSADOR REVERSÍVEL 1550



Acessório para prolongar o passador 1550)

225154

HASTE FECHO 1550.801



211103

PONTO FECHO PAVIMENTO 1409/8

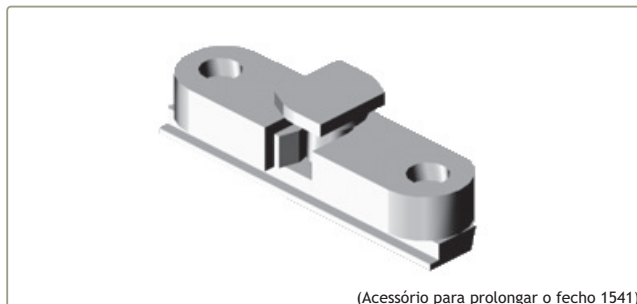

(Acessório para prolongar o fecho 1541)

218206

CLIQUE DE RETENÇÃO 1468

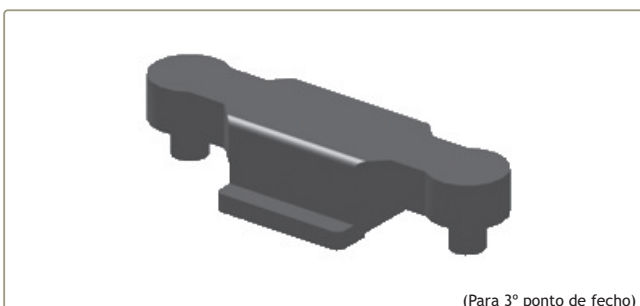

(Para 3º ponto de fecho)

201463

FECHO LATERAL 1243.710

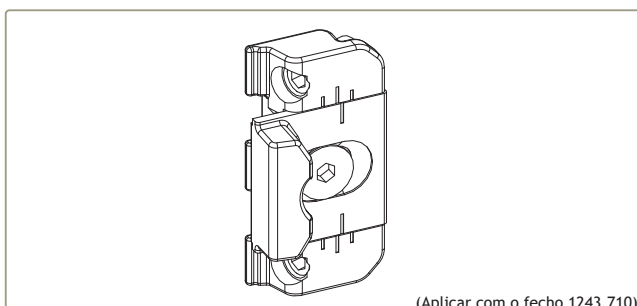

(Aplicar com o fecho 1243.710)

202075

CONTRA-FECHO 1243.721

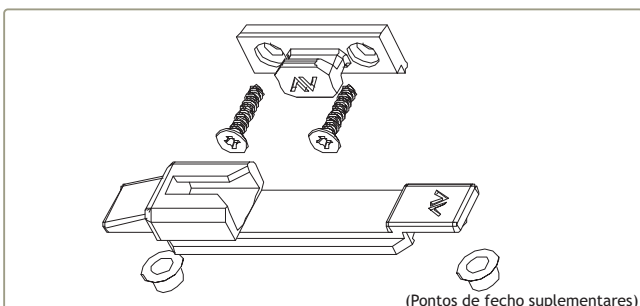

(Pontos de fecho suplementares)

201363

FECHOS ANTI-ARROMBAMENTO 1246.835

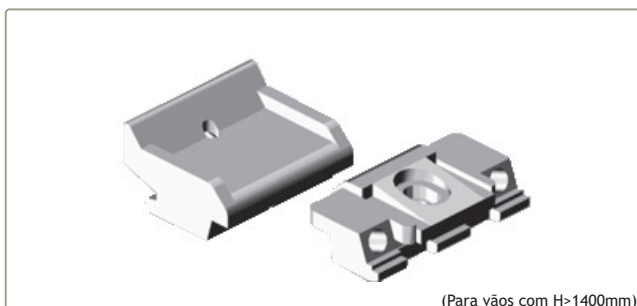

(Para vãos com H>1400mm)

201537

FECHO SUPLEMENTAR 1246.832

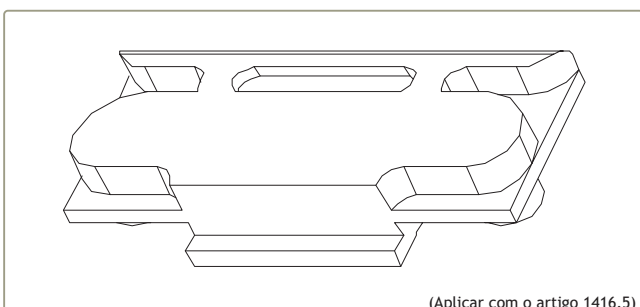

(Aplicar com o artigo 1416.5)

230225

SUPLEMENTO PARA VENTILAÇÃO 1463



(Aplicar com o artigo 1463)

202089

CONTRA-FECHO DUPLO 1416.5

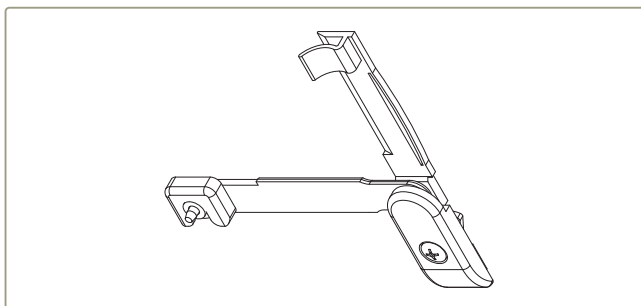

228104 LIMITADOR DE ABERTURA 6060 Pr.

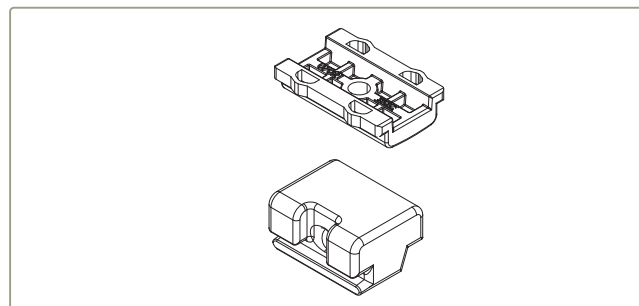

212154 CONJUNTO PARA CALÇO 1410.50 Pr.



200814 PUXADOR SIMPLES 874.2



207511 TAMPA DE PROTECÇÃO 874.805

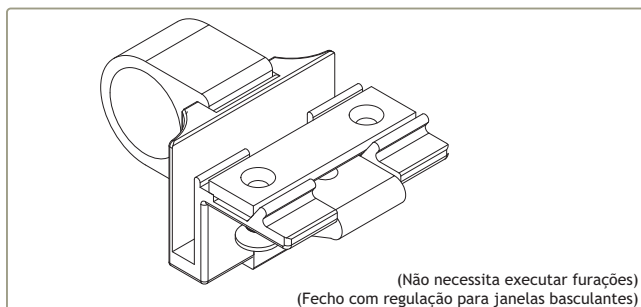

201547 FECHO P/BASCULANTE REGULÁVEL 509R (Br., Pr. ou Cinza)

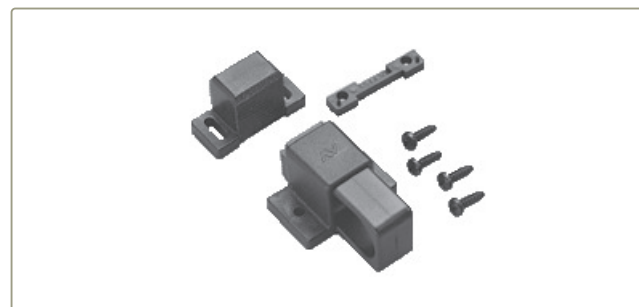

201495 FECHO PARA BASCULANTE 1357



201497 FECHO P/BASCULANTE 1370.1



228010 MECANISMO MONO 1200/8



228117 MECANISMO DUO 1201/8



210114 BRAÇO PIOVRA 1344.4  
210103 BRAÇO PIOVRATRE 1341 (Altura mín. folha = 280mm)





Peso máx. janela basculante = 15Kg  
Peso máx. janela projectante = 30Kg

Altura máxima janela basculante = 600mm

212060

CONJUNTO DOBRADIÇA INOX 1953  
(Para janela basculante ou projectante)



(Para limitar a abertura da folha)

202040

COMPASSO LIMITADOR DE ABERTURA 1343.2



Dimensão do compasso = 152mm  
Altura máxima = 300mm  
Largura máxima = 1200mm  
Peso máximo = 10Kg  
Ângulo de abertura = 50°

212030

CONJUNTO BRAÇO PARA PROJECTANTES S 150

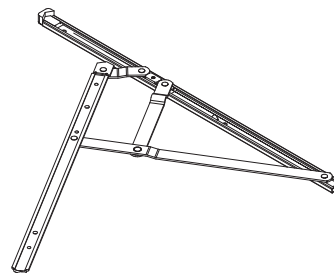

Dimensão do compasso = 415mm  
Altura máxima = 1090mm  
Largura máxima = 2200mm  
Peso máximo = 55Kg  
Ângulo de abertura = 50°

212032

CONJUNTO BRAÇO PROJECTANTE S 400

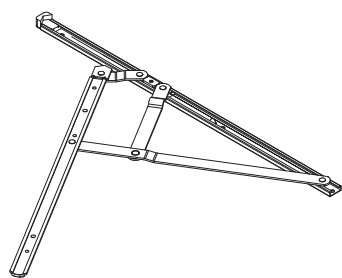

Dimensão do compasso = 567mm  
Altura máxima = 1500mm  
Largura máxima = 1200mm  
Peso máximo = 75Kg  
Ângulo de abertura = 45°

212034

CONJUNTO BRAÇO PROJECTANTE S 550

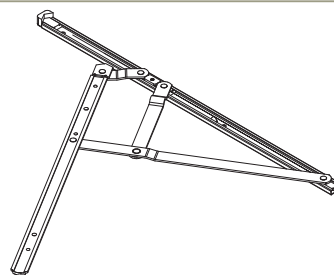

Para vãos até 100Kg  
Dimensão do compasso = 685mm  
Altura máxima = 2000mm  
Altura mínima = 750mm  
Largura máxima = 2200mm  
Ângulo de abertura = 20°

Para vãos até 120Kg (usar com o  
KIT ST 7280)  
Dimensão do compasso = 720mm  
Altura máxima = 2000mm  
Altura mínima = 800mm  
Largura máxima = 2200mm  
Ângulo de abertura = 15°

212021  
223007

CONJUNTO BRAÇO PROJECTANTE ST 26  
KIT AJUSTÁVEL ST 280

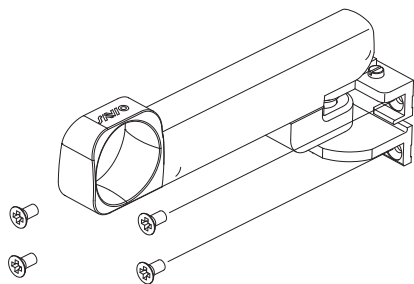

202605  
214253

COMANDO 1206.1/2 LAC. 900  
COMANDO 1206.1/1 LAC. 905



(Para janela projectante com dobradiça)  
(Peso máx. com 2 compassos = 70Kg)

202065

COMPASSO SAVIO 1307.1

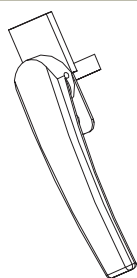

416006

MANÍPULO ARTICULADO BAIXO SOS



(Aplicar com o Manípulo Articulado Baixo SOS)

228210

MECANISMO INTERIOR SOS



(L = 12.8mm)

290101

PARAFUSO PB 12.8 mm



(Aplicar com os cremones 876, 876.751 ou 915.1 e nos cremones 897.2, 897.3 ou 879.751)

223670

KIT MOV. INT. 1475.6

2 Dobradiças = 80 Kg  
3 Dobradiças = 90 Kg

202208

DOBRADIÇA MORSA 1121.1

2 Dobradiças = 90 Kg  
3 Dobradiças = 100 Kg

202104

DOBRADIÇA MORSA 1122

2 Dobradiças = 80 Kg  
3 Dobradiças = 90 Kg

202209

DOBRADIÇA MORSA 1123

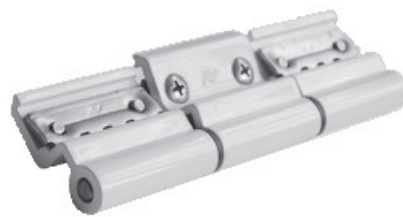
2 Dobradiças = 90 Kg  
3 Dobradiças = 100 Kg

202112

DOBRADIÇA MORSA PARA A 3ª FOLHA 1122.92



CONSULTAR DEPARTAMENTO TÉCNICO

202141

DOBRADIÇA AVANÇO PB 2000



(Dobradiça oculta)

222121

JOGO DOBRADIÇA 3020

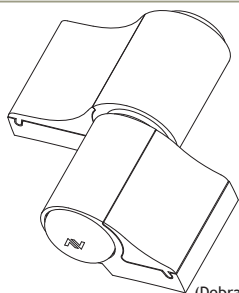
(Dobradiça com regulação nos 3 eixos)  
(Dobradiça certificada para peso máx.=150Kg)

202010

DOBRADIÇA MECHANICA 2 ABAS 1145/60

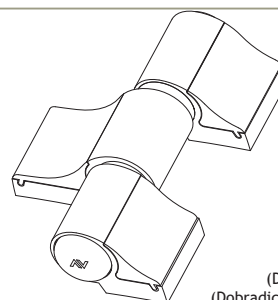
(Dobradiça com regulação nos 3 eixos)  
(Dobradiça certificada para peso máx.=180Kg)202610  
000000DOBRADIÇA MECHANICA 3 ABAS 1145.3/60  
DOBRADIÇA MECHANICA 3 ABAS 1145.3/79

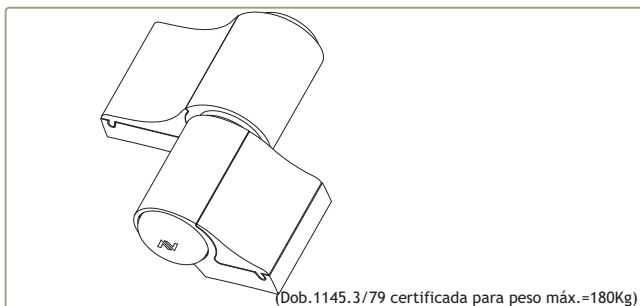

202012

DOBRADIÇA MECHANICA 2 ABAS 1145/79

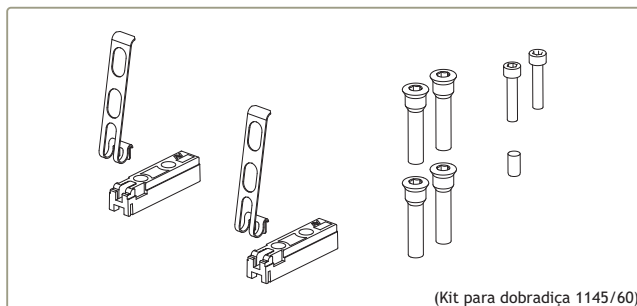

223100

KIT DE FIXAÇÃO PARA MECHANICA 1145.705

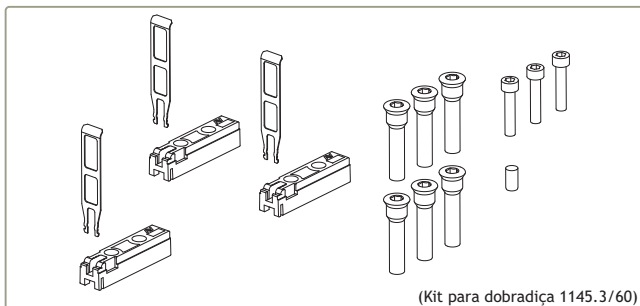

223020

KIT DE FIXAÇÃO PARA MECHANICA 1145.715

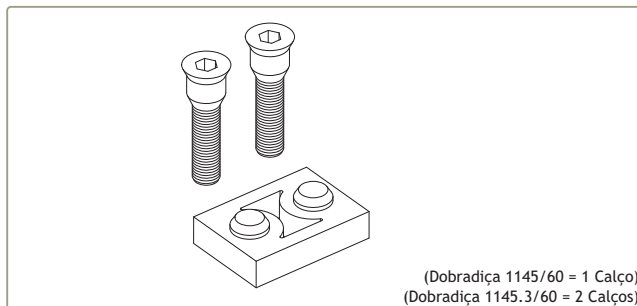

218170

CALÇO PARA DOBRADIÇA MECHANICA 1145.703/7



210011

SEPARADOR 1145.802



210010

SEPARADOR 1125.802



211101

GABARITO PARA FURAÇÃO 1145.908



GABARITO MONTAGEM 1125.951 AC. Nt.



202511

DOBRADIÇA P/ MOLA 1147



202510

DOBRADIÇA 2 ABAS 1132.1/60

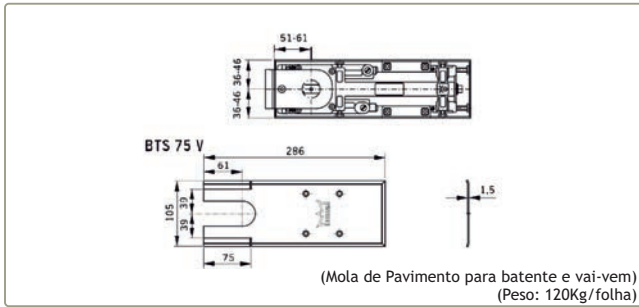

228071 MOLA DE PAVIMENTO BTS 75V

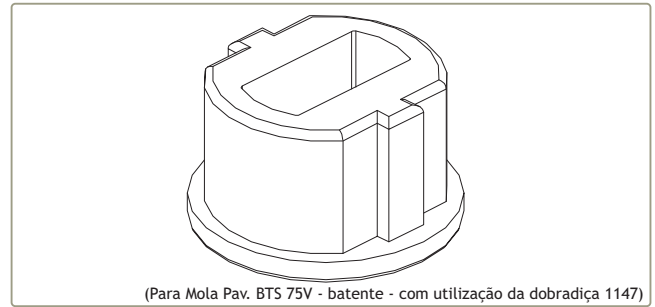

207327 (Para Mola Pav. BTS 75V - batente - com utilização da dobradiça 1147) SEPARADOR R. TER/1129.802 OXID

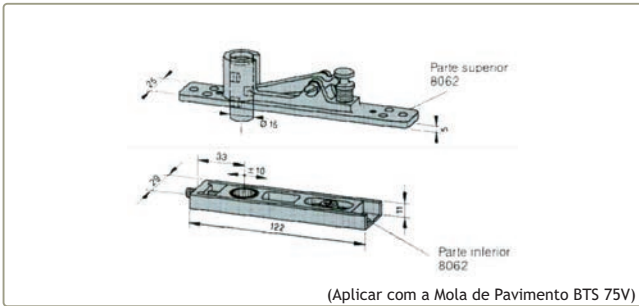

227111 (Aplicar com a Mola de Pavimento BTS 75V) PIVOT SUPERIOR VAI-DEM 8062

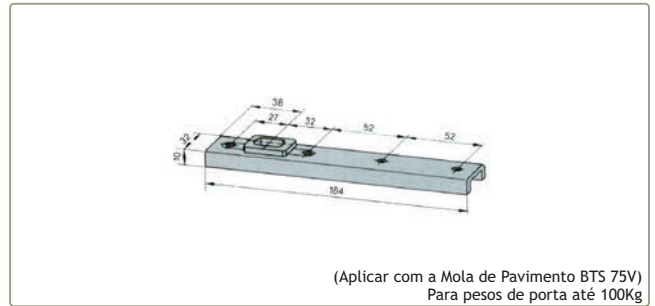

210104 (Aplicar com a Mola de Pavimento BTS 75V) Para pesos de porta até 100Kg BRAÇO INFERIOR VAI-DEM 8021

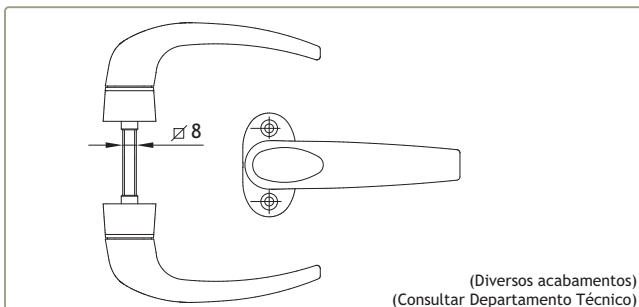

200747 (Diversos acabamentos) (Consultar Departamento Técnico) PUXADOR DUPLO 874.31

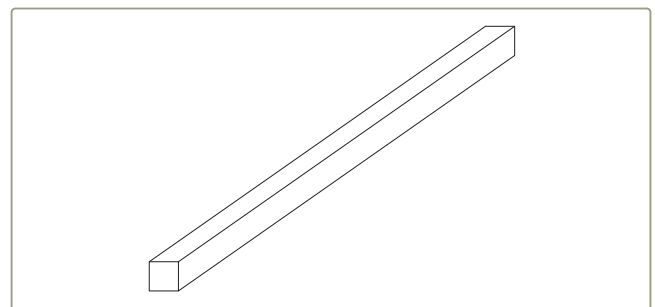

227301 QUADRA AÇO 8mm PARA PUXADOR 874.31

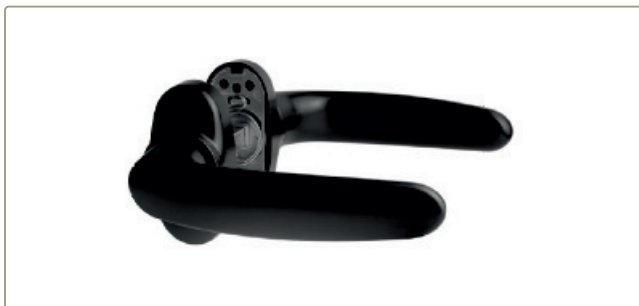

200920 PUXADOR DUPLO 615

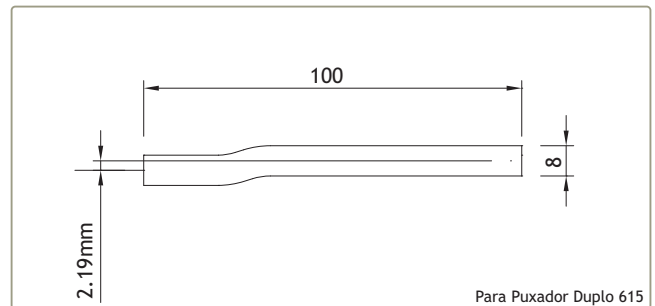

227302 Para Puxador Duplo 615 QUADRA DESCENTRADA 130mm

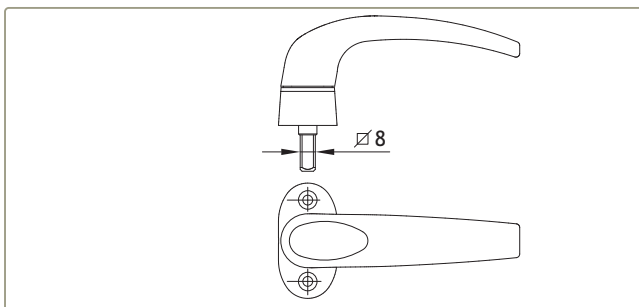

200814 PUXADOR SIMPLES 874.2

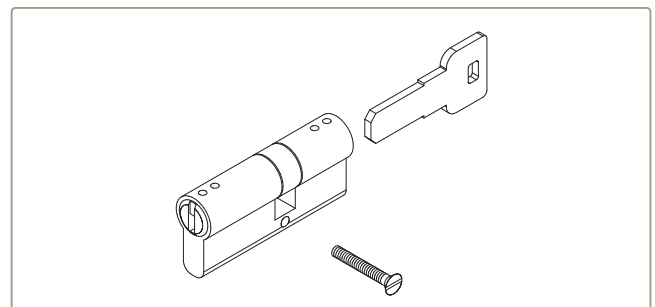

207403 SEGREDO SEGURANÇA 60/30

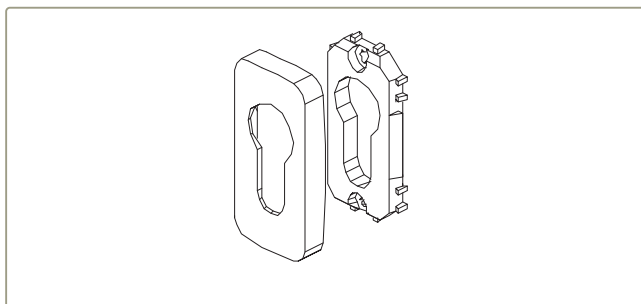

220190

ESPELHO PARA SEGURANÇA 874.801 (Br./Pr.)

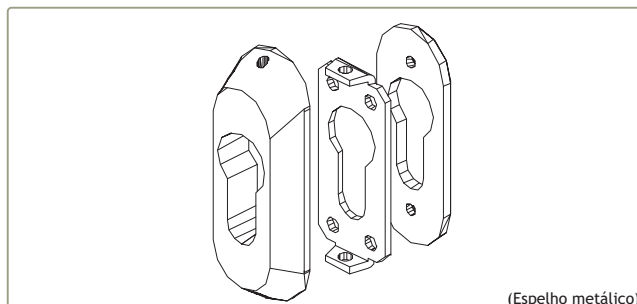

(Espelho metálico)

220008

ESPELHO PARA SEGURANÇA 5100 (Pr.)

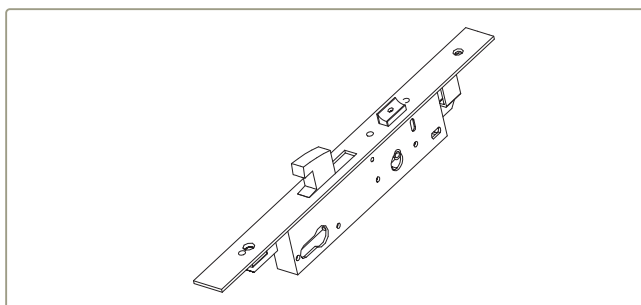
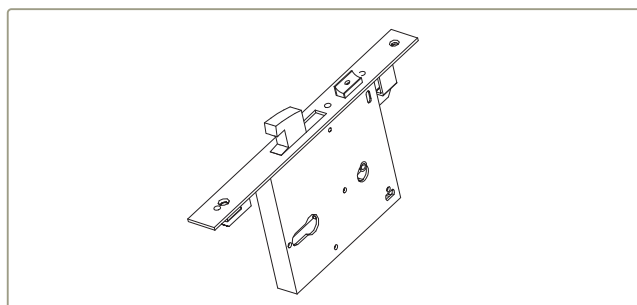
201033  
201034FECHADURA 7797x30  
FECHADURA 7797x35

201013

FECHADURA DE ALMOFADA 5791x90

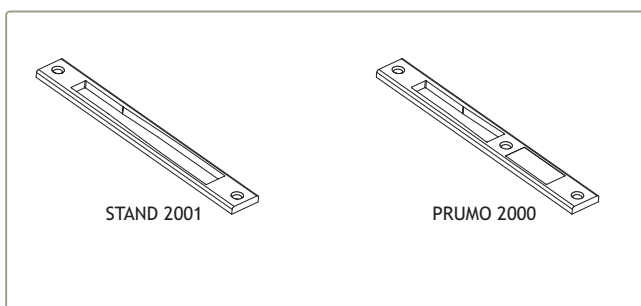

STAND 2001

PRUMO 2000

280230  
280220TESTA FECHADURA STAND 2001  
TESTA FECHADURA PRUMO 2000

280200

TESTA FECHADURA 5791x90

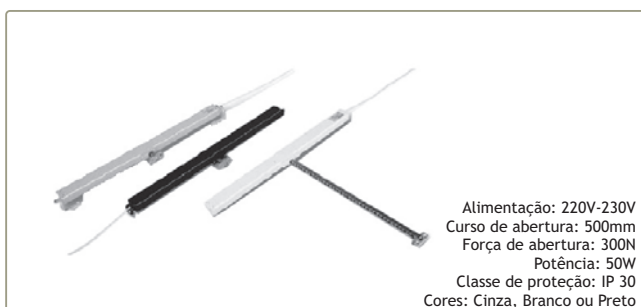

212640

ACIONADOR 40837Z

Alimentação: 220V-230V  
Curso de abertura: 500mm  
Força de abertura: 300N  
Potência: 50W  
Classe de proteção: IP 30  
Cores: Cinza, Branco ou Preto



212036

ACIONADOR ELÉCTRICO DUPLO 240Vac 40989D(Nat.)

Accionador para janelas projetantes e basculantes  
Voltagem: 100Vac - 240Vac  
Inversão de marcha: por inversão de polaridade  
Abertura: 500mm  
Força: 600N  
Classe de proteção: IP 30  
Cores: Natural, Preto, Branco



Cores: Natural, Preto, Branco

230018

SUPORTE PARA MOTOR 40858U



Cores: Natural, Preto, Branco

230463

SUPORTE PARA ACION. ELÉC. DUPLO 41101H(Nat.)

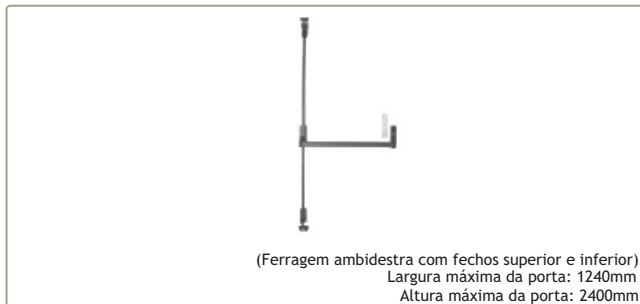

(Ferragem ambidestra com fechos superior e inferior)  
Largura máxima da porta: 1240mm  
Altura máxima da porta: 2400mm

200004

ANTI-PÂNICO VERTICAL KH.2

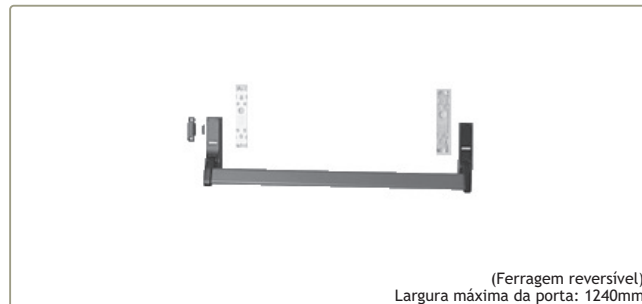

(Ferragem reversível)  
Largura máxima da porta: 1240mm

200001

ANTI-PÂNICO HORIZONTAL KH

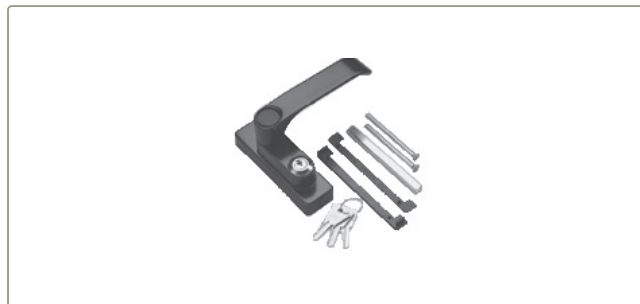

200230

CREMONE COM FECHADURA KH.B.PR.



FERRAGEM CERTIFICADA

(Ferragem reversível)  
Largura máxima da porta: 1240mm  
Altura máxima da porta: 2450mm

200912

ANTI-PÂNICO HORIZONTAL 6000.1/1200

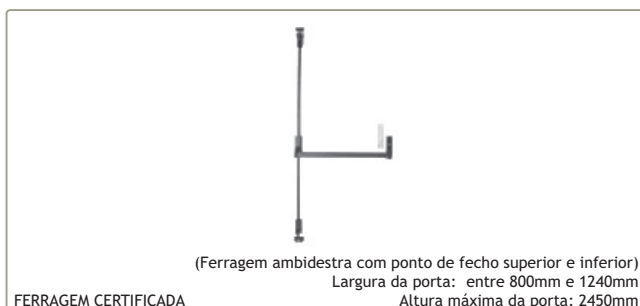

FERRAGEM CERTIFICADA

(Ferragem ambidestra com ponto de fecho superior e inferior)  
Largura da porta: entre 800mm e 1240mm  
Altura máxima da porta: 2450mm

200968

ANTI-PÂNICO VERTICAL 6000.2/1200

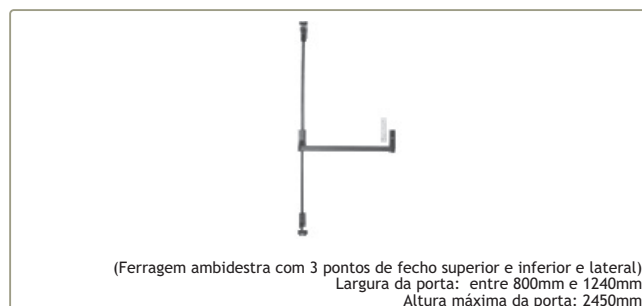

(Ferragem ambidestra com 3 pontos de fecho superior e inferior e lateral)  
Largura da porta: entre 800mm e 1240mm  
Altura máxima da porta: 2450mm

200988

ANTI-PÂNICO VERTICAL 6000.3/1200



FERRAGEM CERTIFICADA

(Ferragem ambidestra com ponto de fecho superior e inferior)  
Largura da porta: entre 800mm e 1240mm  
Altura máxima da porta: 2450mm

000000

ANTI-PÂNICO VERTICAL 6100.2/1085

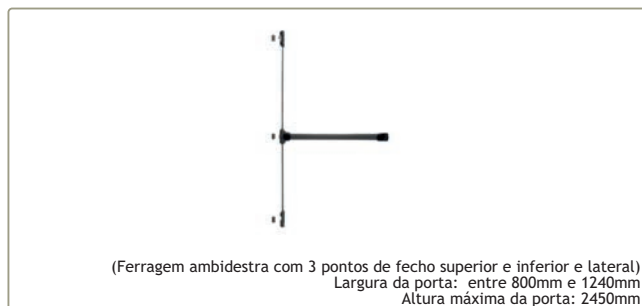

(Ferragem ambidestra com 3 pontos de fecho superior e inferior e lateral)  
Largura da porta: entre 800mm e 1240mm  
Altura máxima da porta: 2450mm

200971

ANTI-PÂNICO VERTICAL 6100.3/1085



FERRAGEM CERTIFICADA

(Ferragem reversível)  
Largura da porta: entre 800mm e 1240mm  
Altura máxima da porta: 2450mm

200970

ANTI-PÂNICO HORIZONTAL 6100.1/1085

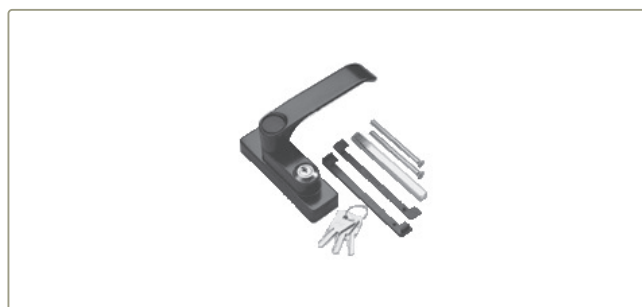

200914

CREMONE COM FECHADURA 6000.875. Pr.

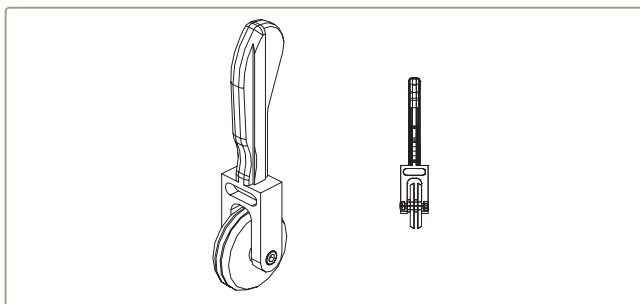

425001

ROLETA P/VED. CPT 150D



426003

TESOURA PARA VEDANTES MULTICOUP

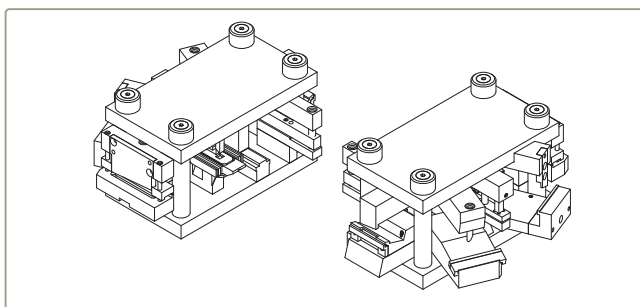

408044

CORTANTE SISTEMA IT/ST

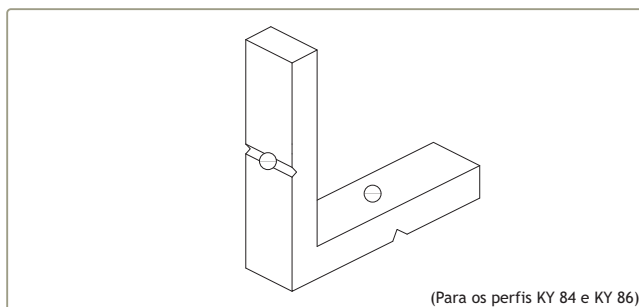

204380

(Para os perfis KY 84 e KY 86)

ESQUADRO 1108

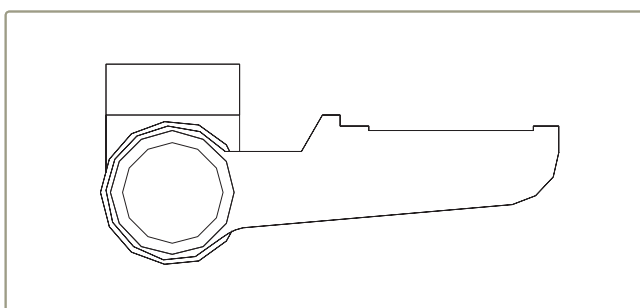

202229

DOBRADIÇA PARA SISTEMA TAPA-LUZ

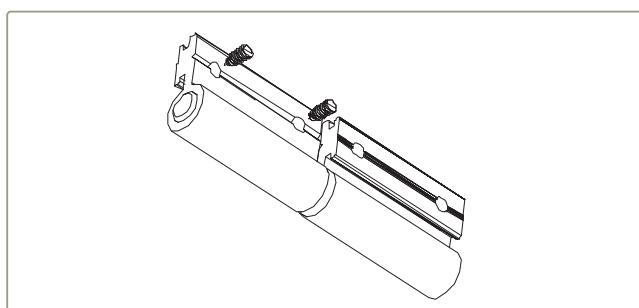

202230

DOBRADIÇA PARA PORTADAS INTERIORES / REDE MOSQUITEIRA

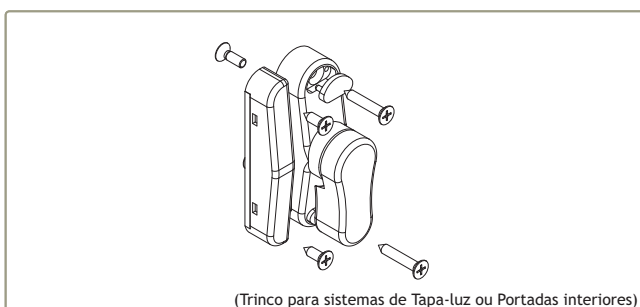

(Trinco para sistemas de Tapa-luz ou Portadas interiores)

231214

TRINCO REVERSÍVEL 9566 (Br. / Pr.)

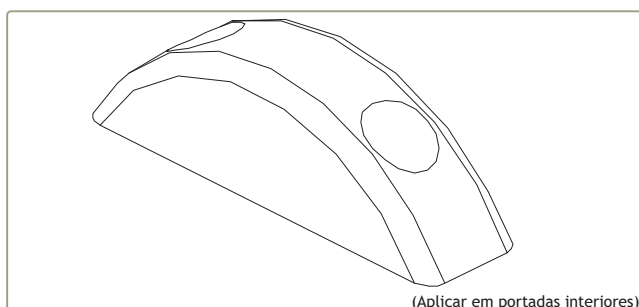

(Aplicar em portadas interiores)

214146

BATENTE PARA PERSIANA 877.804

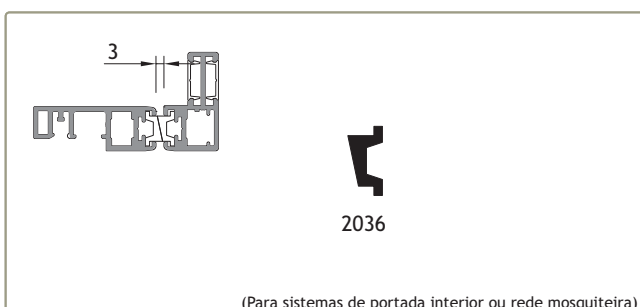

(Para sistemas de portada interior ou rede mosquiteira)

215155

PERFIL MAGNÉTICO 2036

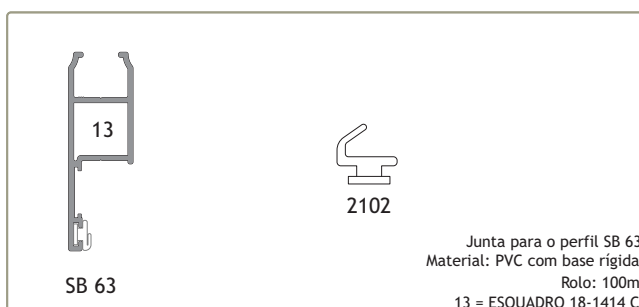

208264

Junta para o perfil SB 63  
Material: PVC com base rígida  
Rolo: 100m  
13 = ESQUADRO 18-1414 C

JUNTA ESTANQUICIDADE 2102



1027  
(Rolo: 100m)

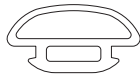

2027  
(Rolo: 25m)

208310  
208261

VEDANTE PARA MOSQUITEIRA 1027 Pr.  
JUNTA ESTANQUICIDADE 2027



217118  
231002

BICHA F604 (POR METRO)  
TUBO F111 ( 3 METROS)

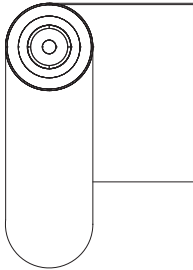

Rolo de 30m x 1,60m

229105

REDE MOSQUITEIRA EM FIBRA



(Puxador para sistema de rede mosquiteira)

200910

PUXADOR SIMPLES SOS



(Sem Bicha e sem Tubo)

223760

KIT PARA BASCULANTE SIMPLES



213124

ACIONADOR MECÂNICO CINZA

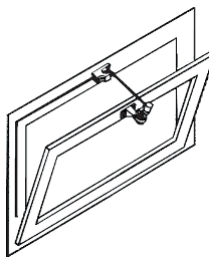

Com Bicha (3m) e com Tubo (3m)

223906

KIT COMPLETO QL. 1 (3m)



220100

DISPOSITIVO MANUAL P18/14

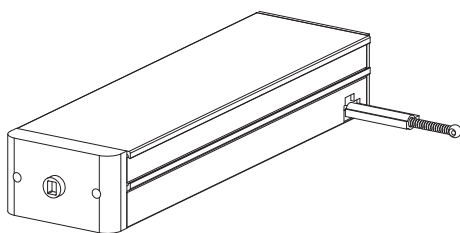

212248

ACIONADOR ELÉTRICO PRT.

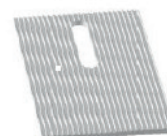

218116

CALÇO SEPARADOR





Presilha M6 x 37 mm  
(Aplicar com os perfis AT 31, AT 60, AT 61 e AT 81)

207220

PRESILHA M6 x 37mm



Presilha M6 x 17 mm  
(Aplicar com os perfis AT 41, AT 51, AT 47, AT 57e DT 57)

207203

PRESILHA M6 x 17mm

213239  
213240ÂNGULO DE FIXAÇÃO 100mm  
ÂNGULO DE FIXAÇÃO 120mm230014  
230019SUPORTE DE FIXAÇÃO 100mm  
SUPORTE DE FIXAÇÃO 120mm

Limpeza de alumínio lacado ou anodizado  
Para preparação das zonas a serem unidas e limpeza final

208704

PRODUTO DE LIMPEZA DE ALUMÍNIO (1L) Transparente



Junta de vedação elástica, resistente aos UV  
Impede a corrosão de penetrar pelas zonas cortadas

208019

SELA JUNTAS 150gr. (Cinza)

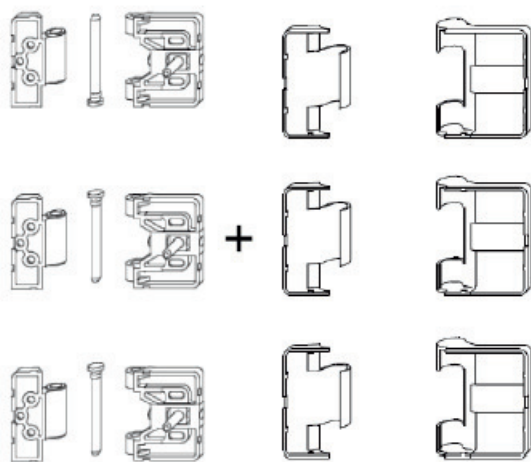

Dobradiças

Coberturas

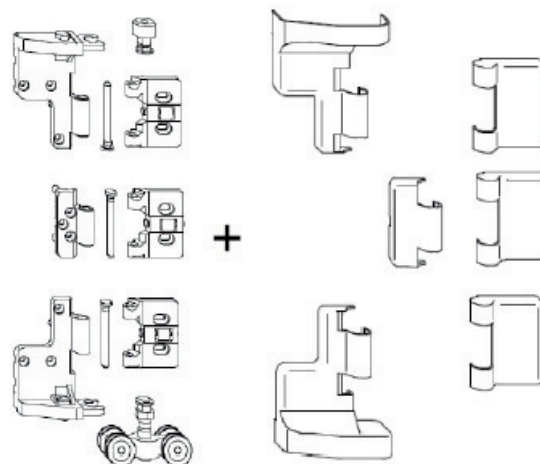
212064  
212879  
212878CONJUNTO DOBRADIÇAS FS-LM BRUTO  
CONJUNTO COBERTURAS P/DOBRADIÇAS FS-LM BRC  
CONJUNTO COBERTURAS P/DOBRADIÇAS FS-LM PRT

Rolamento

Coberturas

212321  
212880  
212877CONJUNTO ROLAM. INTERM. FS-LM BRUTO  
CONJUNTO COBERTURA P/ROLAM.INTERM. FS-LM BRC  
CONJUNTO COBERTURAS P/ROLAM. INTERM. FS-LM PRT

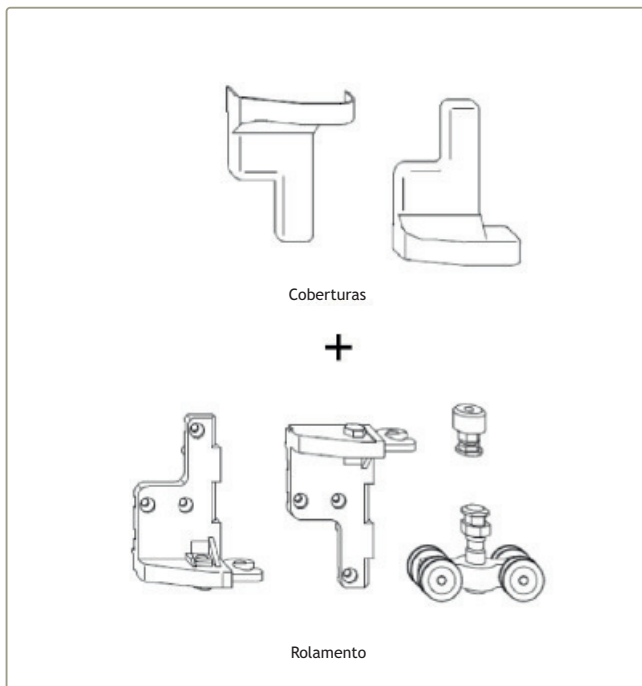

212320 CONJUNTO ROLAM. TERM. FS-LM BRUTO  
 212881 CONJUNTO COBERTURA P/ROLAM. TERM. FS-LM BRC  
 212882 CONJUNTO COBERTURA P/ROLAM. TERM. FS-LM PRT

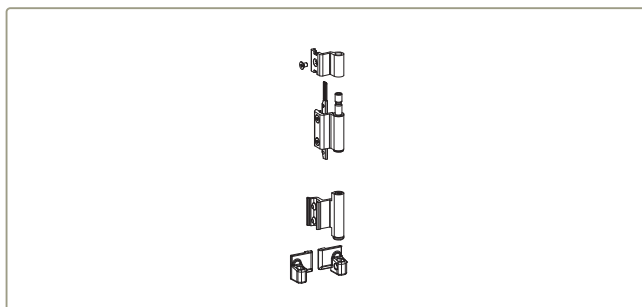

222123 JOGO DOBRADIÇAS 3200.709 RB5 110Kg

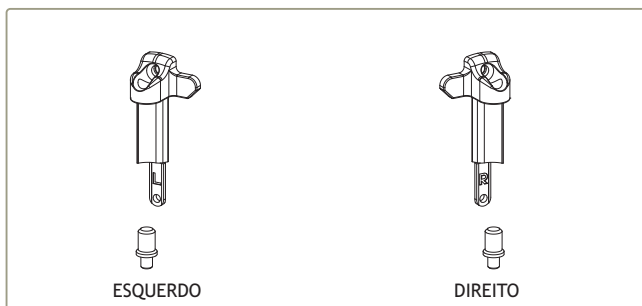

299038 REFORÇO DE DOBRADIÇA PARA 140Kg 3200.708L RB5 ESQ.  
 299039 REFORÇO DE DOBRADIÇA PARA 140Kg 3200.708R RB5 DIR.

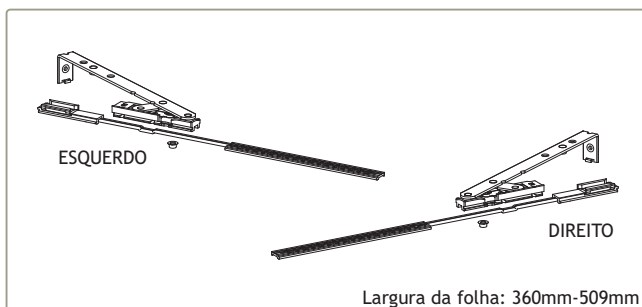

202043 COMPASSO CURTO 3200-750L RB5 ESQ.  
 202044 COMPASSO CURTO 3200-750R RB5 DIR.

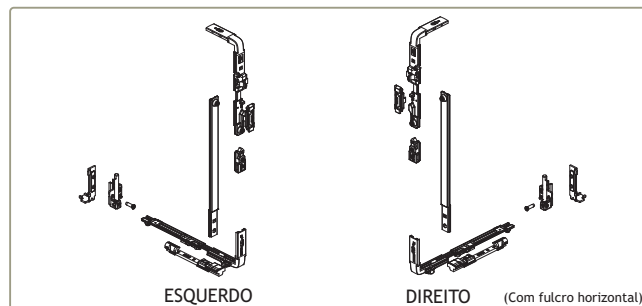

299036 CARTÃO BASE 3200.2L RB5 ESQUERDO  
 299037 CARTÃO BASE 3200.2R RB5 DIREITO (Com fulcro horizontal)

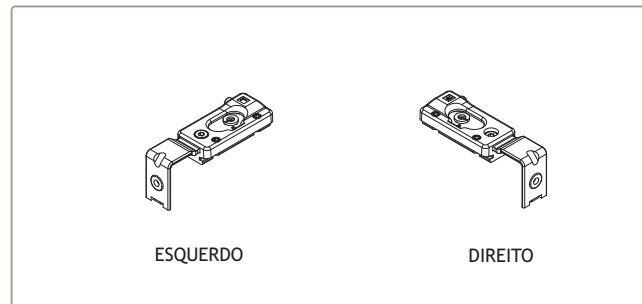

230310 SUPORTE SUPERIOR DE DOBRADIÇAS 3200.840L RB5 ESQ.  
 230311 SUPORTE SUPERIOR DE DOBRADIÇAS 3200.840R RB5 DIR.

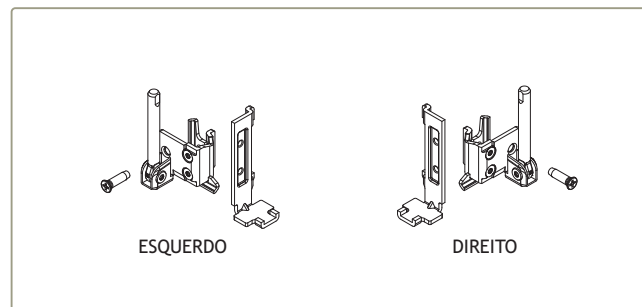

230312 SUPORTE INFERIOR DE DOBRADIÇAS 3200.710L RB5 ESQ.  
 230313 SUPORTE INFERIOR DE DOBRADIÇAS 3200.710LR RB5 DIR.

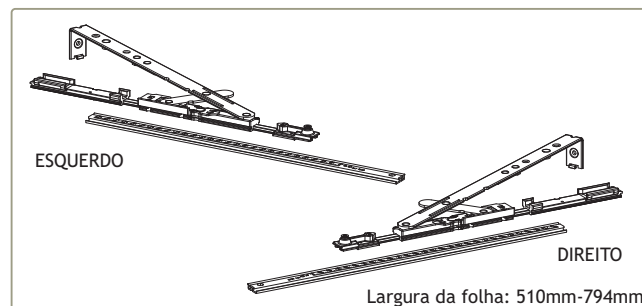

202041 COMPASSO STANDARD 3200.751L RB5 ESQ.  
 202042 COMPASSO STANDARD 3200.751R RB5 DIR.

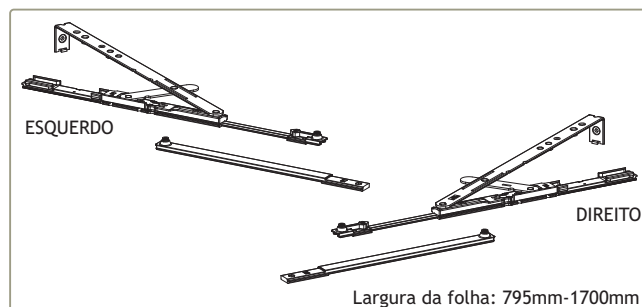

202045 COMPASSO GRANDE 3200-752L RB5 ESQ.  
 202046 COMPASSO GRANDE 3200-752R RB5 DIR.

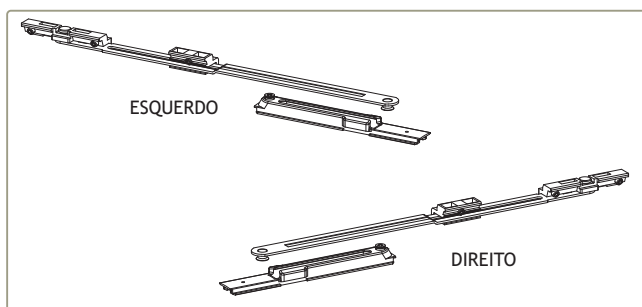

202047  
202048

COMPASSO SUPLEMENTAR 3200.800L HORIZ. RB5 ESQ.  
COMPASSO SUPLEMENTAR 3200.800R HORIZ. RB5 DIR.

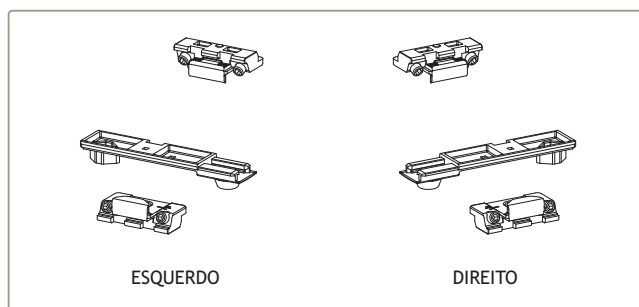

211022  
211023

PONTOS DE FECHO EXTRA 3200.825L HORIZ. RB5 ESQ.  
PONTOS DE FECHO EXTRA 3200.825R HORIZ. RB5 DIR.

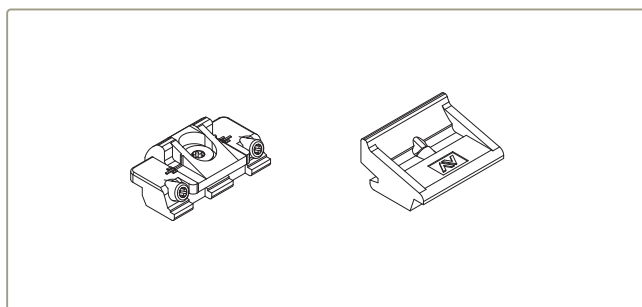

201044

FECHO SUPLEMENTAR 1246.832W RB5

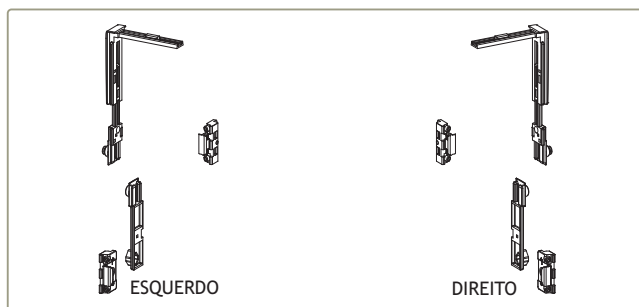

211024  
211025

PONTOS DE FECHO EXTRA 3200.820L VERT. RB5 ESQ.  
PONTOS DE FECHO EXTRA 3200.820R VERT. RB5 DIR.

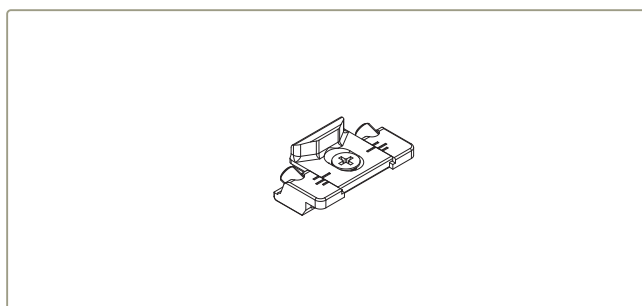

211026

PONTO DE FECHO SUPLEMENTAR FIXO 1243.721W RB5

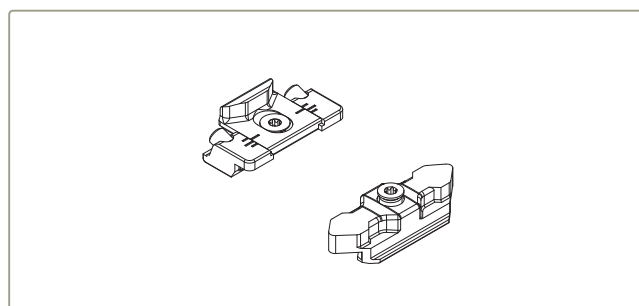

211027

PONTO DE FECHO SUPLEMENTAR FIXO/MÓVEL 3200.810 RB5

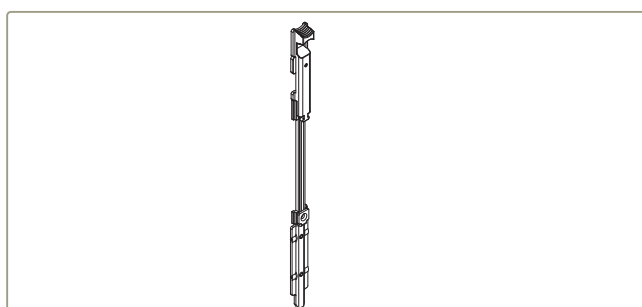

225168

PASSADOR COM PONTEIRA INOX RB5

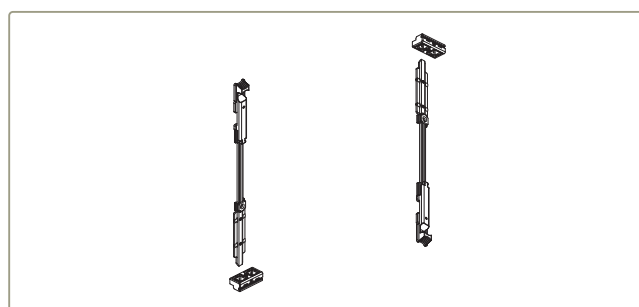

212091

CONJ. FECHOS PASSADOR 2ª FOLHA Inox F3200.851.92 RB5

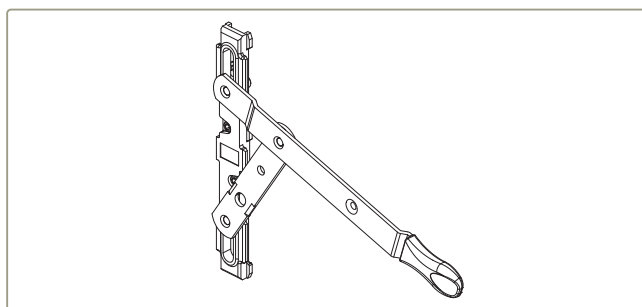

225169

PASSADOR DE ALAVANCA BIDIRECIONAL RB5

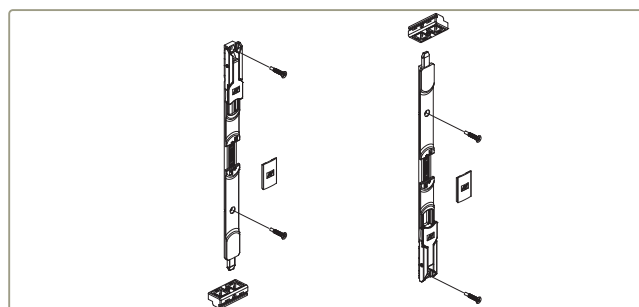

212095

CONJUNTO FECHOS DE ALAVANCA 2ª FOLHA F1539 RB5

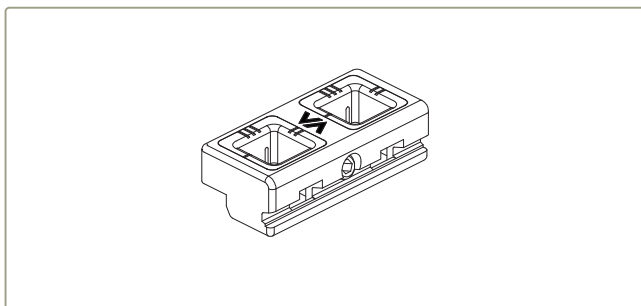

202316 CONTRA-FECHO DUPLO REG. 1414W RB5

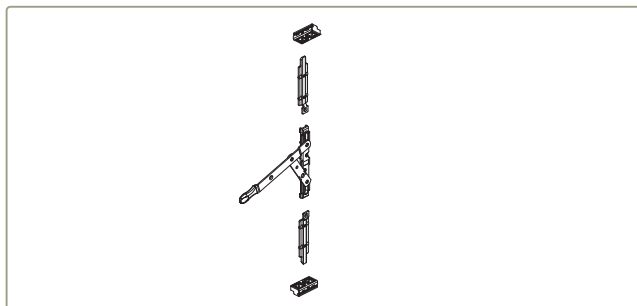

212139 CONJ. FECHO ALAV. BIDIRECIONAL 2ª FOLHA Inox F1538.4 RB5

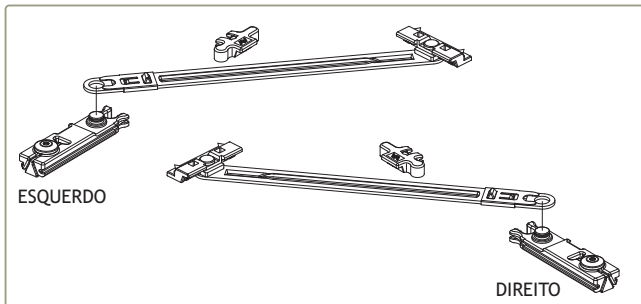

202049 COMP. LIMITADOR C/RETENÇÃO 200mm 1343.8L /20 RB5 ESQ.  
202055 COMP. LIMITADOR C/RETENÇÃO 200mm 1343.8R /20 RB5 DIR.

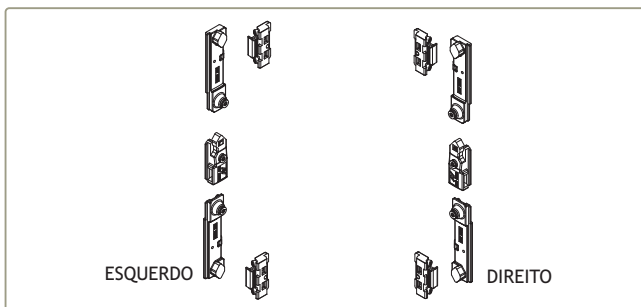

223021 KIT 1 FOLHA BATENTE 3200.600L RB5 ESQ.  
223022 KIT 1 FOLHA BATENTE 3200.600R RB5 DIR.

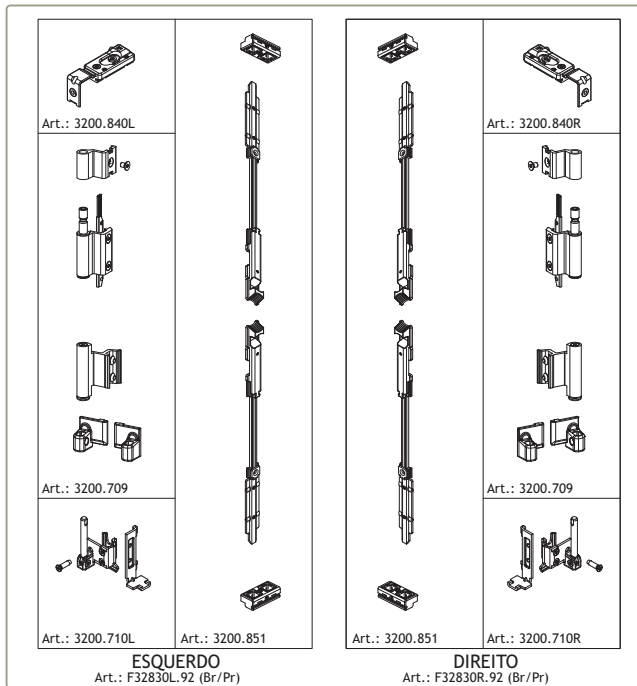

223023 KIT 2ª FOLHA F32830L.92 RB5 ESQ.  
223024 KIT 2ª FOLHA F32830R.92 RB5 DIR.

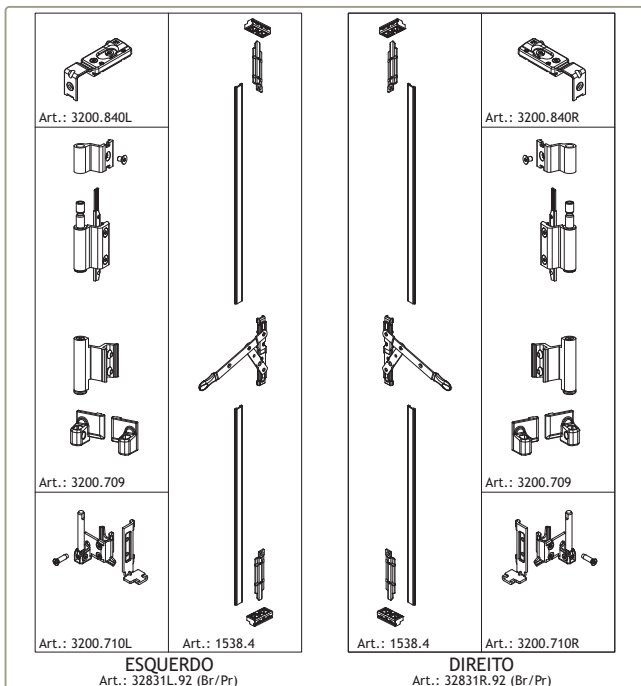

223025 KIT 2ª FOLHA BIDIRECIONAL F32831L.92 RB5 ESQ.  
223026 KIT 2ª FOLHA BIDIRECIONAL F32831R.92 RB5 DIR.

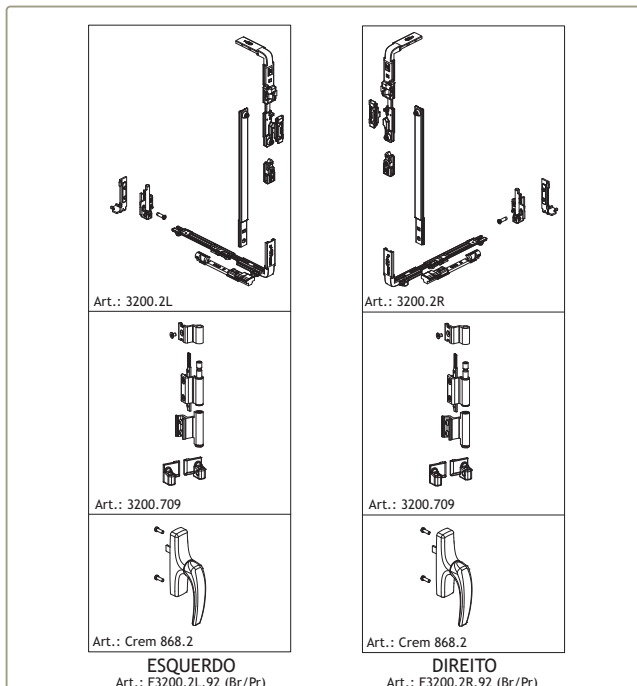

223027 KIT OSCILO-BAT 1 FOLHA S/COMPASSO F3200.2L.92 RB5 ESQ.  
223028 KIT OSCILO-BAT 1 FOLHA S/COMPASSO F3200.2R.92 RB5 DIR.



## **Pormenores de montagem**

Assembly details  
Détails de montage





**JANELA DE BATENTE DE 1 FOLHA - LINHA RETA**

1 LEAF CASEMENT WINDOW - STRAIGHT LINE

FENÊTRE À LA FRANÇAISE 1 VANTAIL - LIGNE DROITE

PERFIS PROFILES   PROFILS				
REFERÊNCIA REFERENCE RÉFÉRENCE	CORTE HORIZONTAL HORIZONTAL DETAIL DÉTAIL HORIZONTAL	CORTE VERTICAL VERTICAL DETAIL DÉTAIL VERTICALE	QUANTIDADE QUANTITY QUANTITÉ	CORTE CUT COUPÉ
IT-01	L-6	H-6	2+2	
IT-02	L-48	H-48	2+2	
-	L-136	H-176	2+2	
SA-33	-----	(H-290)/2	2	

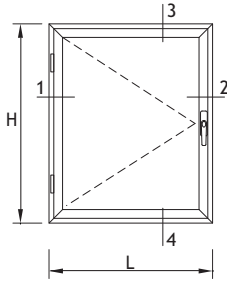

ACESSÓRIOS ACCESSORIES   ACCESSOIRES		
CÓDIGO CODE	DESIGNAÇÃO DESIGNATION   DÉSIGNATION	QUANTIDADE QUANTITY   QUANTITÉ
210154	GOTEIRA 1875   DRIP   GOUTIÈRE	2
213261	CANTO ALINHAMENTO S IT/ST   ALIGNMENT CORNER   COIN ALIGNEMENT	4
213259	CANTO CR 0018   ANGLE   COIN	8
204142	ESQUADRO IT/ST Nº5 18-2512-140   BLOCKING BRACKET   ÉQUERRE	4
204137	ESQUADRO IT/ST Nº1 16-1914-C   BLOCKING BRACKET   ÉQUERRE	4
202208	DOBRADIÇA 1121.1   HINGE   PAUMELLE	2
200302	CREMONE 870.2   HANDLE   POIGNÉE	1
215114	PEÇA CREMONE VARETA 1481   OPERATING ROD PIECE   ENTRÂINEUR	2
206490	TERMINAL VARETA 1486   LOCKING TERMINAL   TERMINAISON DE FERMETURE	2
202090	CONTRA-FEC. DUPL0 1416.6   DOUBLE COUNTER-LOCK   CONTRE-FERM. DOUBLE	2
218194	CALÇOS P/VIDROS EURO 2000   GLAZING SHIM   CALE POUR VITRAGE	4

VEDANTES SEALANTS   JOINTS		
CÓDIGO CODE	DESIGNAÇÃO DESIGNATION   DÉSIGNATION	QUANTIDADE QUANTITY   QUANTITÉ
208145	VD 2079	2L+2H
208008	VD 2051 (1)	2L+2H
208184	VD 2412 (opcional   optional   optionnel)	2L+2H
208186	VD 2105 (2)	2L+2H
208350	VD 2003	2L+2H
VARIÁVEL VARIABLE	JUNTA INTERIOR   GLAZING WEDGE GASKET   JOINT INTÉRIEUR	2L+4H
213290	CANTO VULCANIZADO 2105.1   CORNER JOINT   JOINT VULCANISÉ	4

(1) 208143 VD 2071 (alternativa ao VD 2051 | alternative | alternative)  
 (2) 208144 VD 2305 (alternativa ao VD 2105 | alternative | alternative)

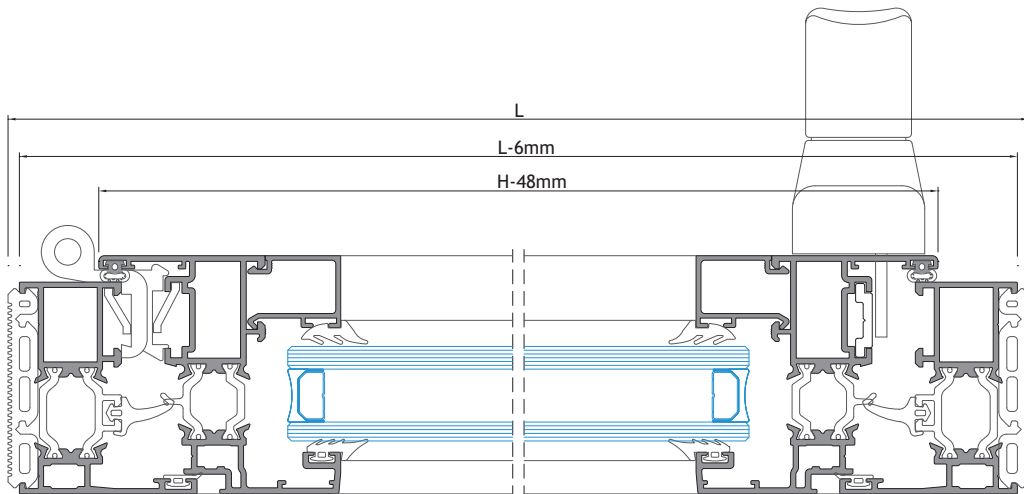
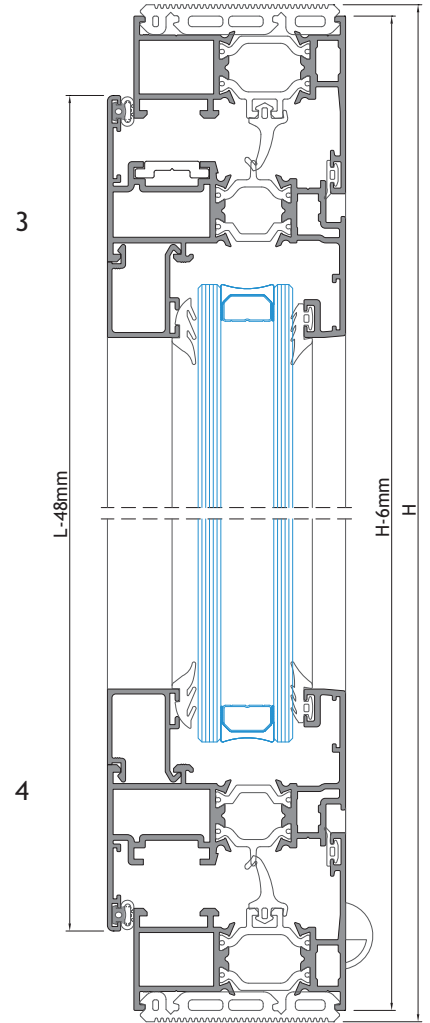

ESC: 1/2



# JANELA DE BATENTE 2 FOLHAS - LINHA RETA

2 LEAVES CASEMENT WINDOW - STRAIGHT LINE

FENÊTRE À LA FRANÇAISE 2 VANTAUX - LIGNE DROITE

PERFIS PROFILES   PROFILS				
REFERÊNCIA REFERENC RÉFÉRENCE	CORTE HORIZONTAL HORIZONTAL DETAIL DÉTAIL HORIZONTAL E	CORTE VERTICAL VERTICAL DETAIL DÉTAIL VERTICALE F	QUANTIDADE QUANTITY QUANTITÉ	CORTE CUT COUPÉ
IT-01	L-6	H-6	2+2	
IT-02	(L-55)/2	H-48	4+4	
IT-06	.....	H-118	1	
-	(L-231)/2	H-176	4+4	
SA-33	.....	(H-290)/2	2	

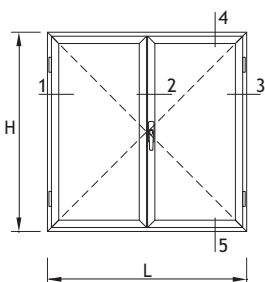

ACESSÓRIOS ACCESSORIES   ACCESSOIRES		
CÓDIGO CODE	DESIGNAÇÃO DESIGNATION   DÉSIGNATION	QUANTIDADE QUANTITY   QUANTITÉ
210154	GOTEIRA 1875   DRIP   GOUTIÈRE	2
213261	CANTO ALINHAMENTO S IT/ST   ALIGNMENT CORNER   COIN ALIGNEMENT	8
213259	CANTO CR 0018   ANGLE   COIN	12
204142	ESQUADRO IT/ST Nº5 18-2512-140   BLOCKING BRACKET   ÉQUERRE	8
204137	ESQUADRO IT/ST Nº1 16-1914-C   BLOCKING BRACKET   ÉQUERRE	4
202208	DOBADIÇA 1121.1   HINGE   PAUMELLE	4
200302	CREMONE 870.2   HANDLE   POIGNÉE	1
215114	PEÇA CREMONE VARETA 1481   OPERATING ROD PIECE   ENTRAÎNEUR	2
206490	TERMINAL VARETA 1486   LOCKING TERMINAL   TERMINAISON DE FERMETURE	2
202090	CONTRA-FEC. DUPLO 1416.6   DOUBLE COUNTER-LOCK   CONTRE-FERM. DOUBLE	2
218194	CALÇOS P/VIDRO EURO2000   GLAZING SHIM   CALE POUR VITRAGE	8
212063	CONJ. TOPO INVERSOR IT   END CAP KIT   KIT EMBOUTS	1
201490	FECHO P/2*FOLHA 1541   2ND LEAF LOCKER   FERMETURE POUR 2EME VANTAIL	2

VEDANTES SEALANTS   JOINTS		
CÓDIGO CODE	DESIGNAÇÃO DESIGNATION   DÉSIGNATION	QUANTIDADE QUANTITY   QUANTITÉ
208145	VD 2079	2L+2H
208008	VD 2051 (1)	2L+3H
208184	VD 2412 (opcional   optional   optionnel)	2L+3H
208186	VD 2105 (2)	2L+3H
208350	VD 2003	2L+4H
VARIÁVEL VARIABLE	JUNTA INTERIOR   GLAZING WEDGE GASKET   JOINT INTÉRIEUR	2L+4H
213290	CANTO VULCANIZADO 2105.1   CORNER JOINT   JOINT VULCANISÉ	4

(1) 208143 VD 2071 (alternativa ao VD 2051 | alternative | alternative)  
 (2) 208144 VD 2305 (alternativa ao VD 2105 | alternative | alternative)

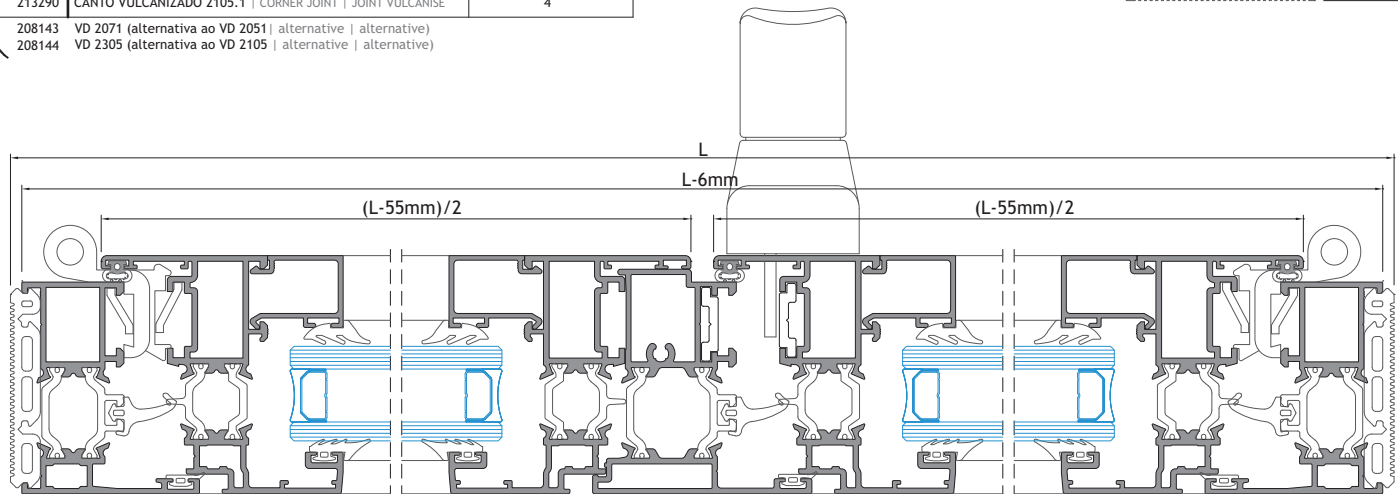
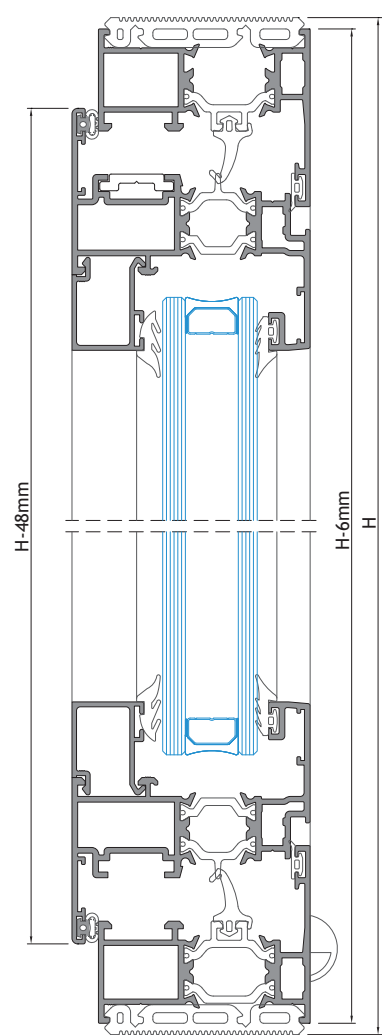



## PORTA DE 1 FOLHA - ABERTURA PARA INTERIOR

1 LEAF DOOR - INWARD OPENING

PORTE À 1 VANTAIL - OUVERTURE VERS L'INTÉRIEUR

PERFIS PROFILES   PROFILS				
REFERÊNCIA REFERENCE RÉFÉRENCE	CORTE HORIZONTAL HORIZONTAL DETAIL DÉTAIL HORIZONTAL	CORTE VERTICAL VERTICAL DETAIL DÉTAIL VERTICALE	QUANTIDADE QUANTITY QUANTITÉ	CORTE CUT COUPÉ
IT-07	L-6	H-3	1+2	
IT-11	L-84	H-56	2+2	
IT-49	L-86	-	1	
IT-32	L-151	-	1	
-	L-208	H-220	2+2	

ACESSÓRIOS ACCESSORIES   ACCESSOIRES		
CÓDIGO CODE	DESIGNAÇÃO DESIGNATION   DÉSIGNATION	QUANTIDADE QUANTITY   QUANTITÉ
213246	CANTO CR 5/SB   ANGLE   COIN	4
204139	ESQUADRO IT/ST Nº3 16-1931-C   BLOCKING BRACKET   ÉQUERRE	2
204143	ESQUADRO IT/ST Nº6 18-2530-140   BLOCKING BRACKET   ÉQUERRE	4
213247	CANTO CR 0182   ANGLE   COIN	6
202010	DOBRADIÇA MECANICA 1145/60   HINGE   PAUMELLE	2
223100	KIT FIXAÇÃO 1145.705   FIXATION KIT   KIT FIXATION	2
218170	CAÇCO 1145.703/7   SHIM   CALE	2
201033	FECHADURA 7797x30   LOCKER   SERRURE	1
207403	SEGREDO 60/30   CYLINDER LOCK   CYLINDRE DE SERRURE	1
220008	ESPELHO P/SEGREDO 5100   CYLINDER BACK PLATE   COUVERCLE DE CYLINDRE	1
200747	PUXADOR DUPLO 874.3   HANDLE   POIGNÉE	1
227301	QUADRA AÇO 8X140   STEEL SQUARE SHAFT   BARRE SECTION CARRÉE	1
280220	TESTA FECHADURA PRUMO 2000   STRICKING PLATE   GÂCHE	1
212346	CONJUNTO TAPA-TOPOS SA32   END-CAP KIT   KIT DE EMBOUTE	1
218194	CALÇOS P/VIDRO EURO2000   GLAZING SHIM   CALE P/VITRAGE	4
212069	CONJ. TOPO INVERSOR ST   END-CAP KIT   EMBOUTS	-

VEDANTES SEALANTS   JOINTS		
CÓDIGO CODE	DESIGNAÇÃO DESIGNATION   DÉSIGNATION	QUANTIDADE QUANTITY   QUANTITÉ
208145	VD 2079	L+2H
208008	VD 2051 (1)	2L+2H
208184	VD 2412 (opcional   optional   optionnel)	L+2H
208186	VD 2105 (2)	L+2H
208350	VD 2003	2L+2H
VARIÁVEL VARIABLE	JUNTA INTERIOR   GLAZING WEDGE GASKET   JOINT INTÉRIEUR	2L+2H
213290	CANTO VULCANIZADO 2105.1   CORNER JOINT   JOINT VULCANISÉ	2
208294	VR 3180	2L
208246	VD 1140	L

- (1) 208143 VD 2071 (alternativa ao VD 2051 | alternative | alternative)  
 (2) 208144 VD 2305 (alternativa ao VD 2105 | alternative | alternative)

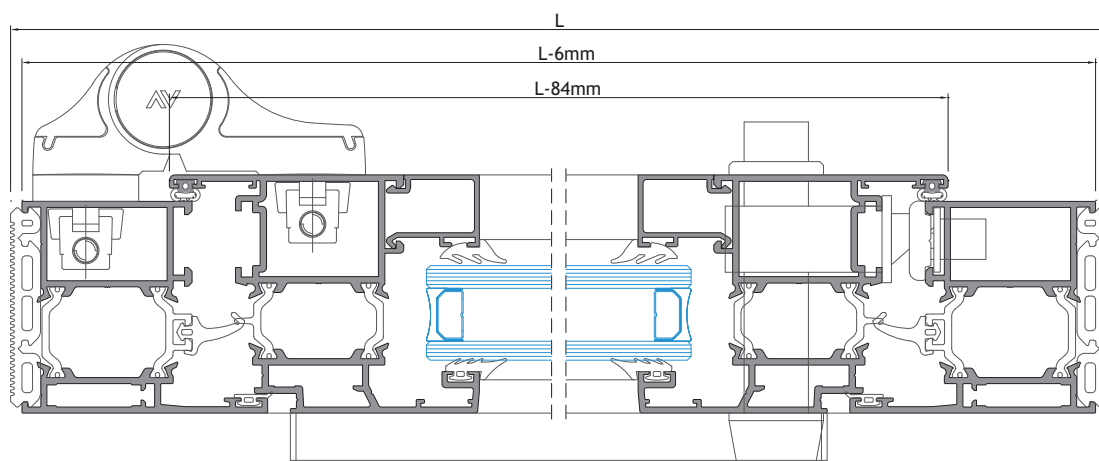
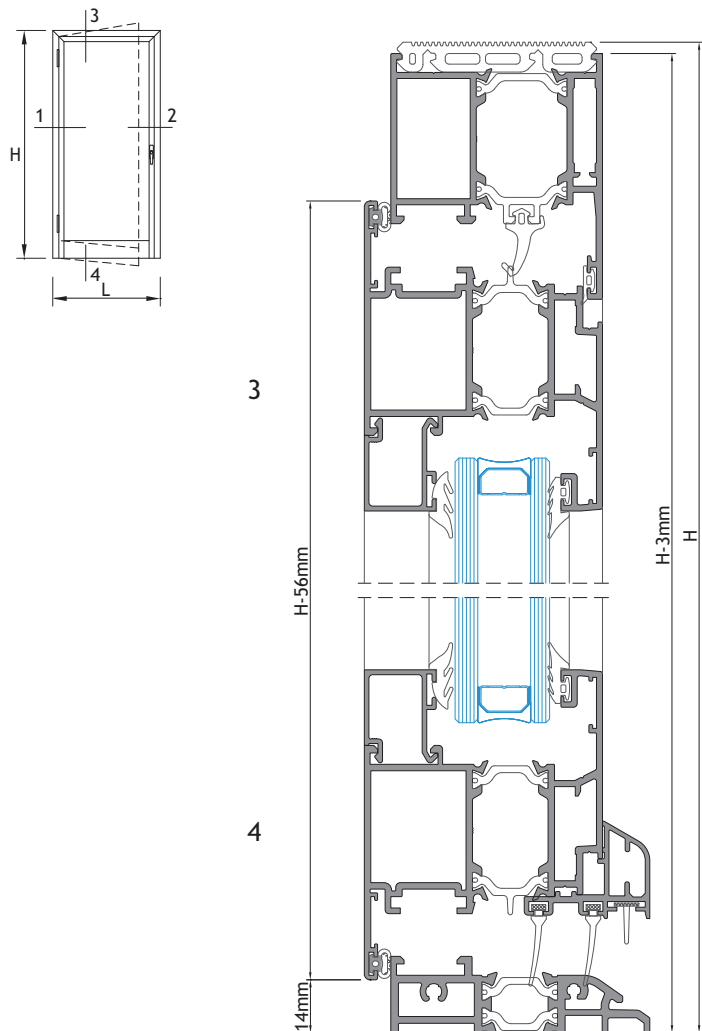

**PORTA DE 2 FOLHAS - ABERTURA PARA INTERIOR**

2 LEAVES DOOR - INWARD OPENING

PORTE 2 VANTAUX - OUVERTURE VERS L'INTÉRIEUR

PERFIS PROFILES   PROFILS				
REFERÊNCIA REFERENCE RÉFÉRENCE	CORTE HORIZONTAL HORIZONTAL DETAIL DÉTAIL HORIZONTAL	CORTE VERTICAL VERTICAL DETAIL DÉTAIL VERTICALE	QUANTIDADE QUANTITY QUANTITÉ	CORTE CUT COUPÉ
IT-07	L-6	H-3	1+2	
IT-11	(L-91)/2	H-49	2+4	
IT-06	-	H-83	1	
IT-14	(L-314)/2	-	2	
SA-31	(L-291)/2	-	2	
SA-32	[(L-220)/2+65] (L-220)/2	-	1+1	
-	(L-339)/2	H-281	4+4	
AT-59	(L-339)/2	-	2	

ACESSÓRIOS ACCESSORIES   ACCESSOIRES		
CÓDIGO CODE	DESIGNAÇÃO DESIGNATION   DÉSIGNATION	QUANTIDADE QUANTITY   QUANTITÉ
213246	CANTO CR S/SB   ANGLE   COIN	4
204139	ESQUADRO IT/ST Nº3 16-1931-C   BLOCKING BRACKET   ÉQUERRE	2
204143	ESQUADRO IT/ST Nº6 18-2530-140   BLOCKING BRACKET   ÉQUERRE	4
213247	CANTO CR 0182   ANGLE   COIN	6
202010	DOBRADIÇA MECANICA 1145/60   HINGE   PAUMELLE	4
223100	KIT FIXAÇÃO 1145.705   FIXATION KIT   KIT FIXATION	4
218170	CAÇÓ 1145.703/7   SHIM   CALE	4
201033	FECHADURA 7797x30   LOCKER   SERRURE	1
207403	SEGREDO 60/30   CYLINDER LOCK   CYLINDRE DE SERRURE	1
220008	ESPELHO P/SEGREDO 5100   CYLINDER BACK PLATE   COUVERCLE DE CYLINDRE	1
200747	PUXADOR DUPLO 874.3   HANDLE   POIGNÉE	1
227301	QUADRA AÇO 8X140   STEEL SQUARE SHAFT   BARRE SECTION CARRÉE	1
280220	TESTA FECHADURA PRUMO 2000   STRICKING PLATE   GÂCHE	1
212346	CONJUNTO TAPA-TOPOS SA32   END-CAP KIT   KIT DE EMBOUTE	2
218194	CAÇOS P/VIDRO EURO2000   GLAZING SHIM   CALE P/VITRAGE	8
212063	CONJ. TOPO INVERSOR IT   END-CAP KIT   EMBOUTS	1
225155	PASSADOR REVERSÍVEL 1550   2ND LEAF LOCKER   FERMETURE POUR 2ÈME VANTAUX	2
225154	HASTE-FECHO 1550.801   EXTENSION ROD   HAMPE D'EXTENSION	1
202077	CONTRA-FECHO 1404   COUNTER-LOCK   CONTRE-FERMETURE	2
211103	PONTO-FECHO PAVIMENTO 1409/8   FLOOR KEEPER   POINT DE CLÔTURE	1

VEDANTES SEALANTS   JOINTS		
CÓDIGO CODE	DESIGNAÇÃO DESIGNATION   DÉSIGNATION	QUANTIDADE QUANTITY   QUANTITÉ
208145	VD 2079	L+2H
208008	VD 2051 (1)	2L+3H
208184	VD 2412 (opcional   optional   optionnel)	L+3H
208186	VD 2105 (2)	2L+3H
208350	VD 2003	2L+4H
VARIÁVEL VARIABLE	JUNTA INTERIOR   GLAZING WEDGE GASKET   JOINT INTÉRIEUR	2L+4H
213290	CANTO VULCANIZADO 2105.1   CORNER JOINT   JOINT VULCANISÉ	2
208464	PELÚCIA 8.5x12 STOP-FIN   PLUSH   JOINT BROSSE	2L

(1) 208143 VD 2071 (alternativa ao VD 2051 | alternative | alternative)  
 (2) 208144 VD 2305 (alternativa ao VD 2105 | alternative | alternative)

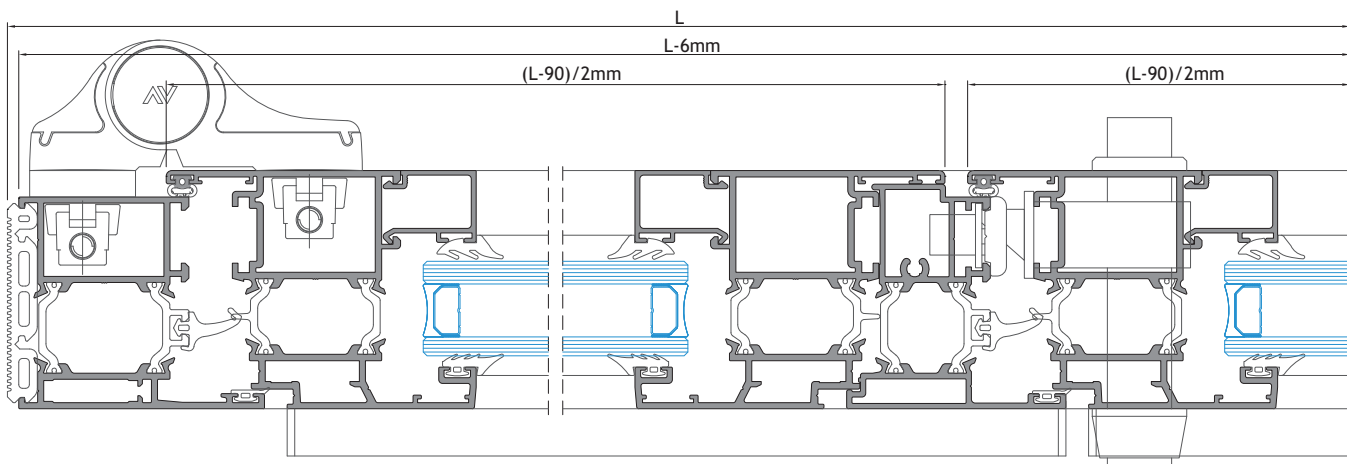
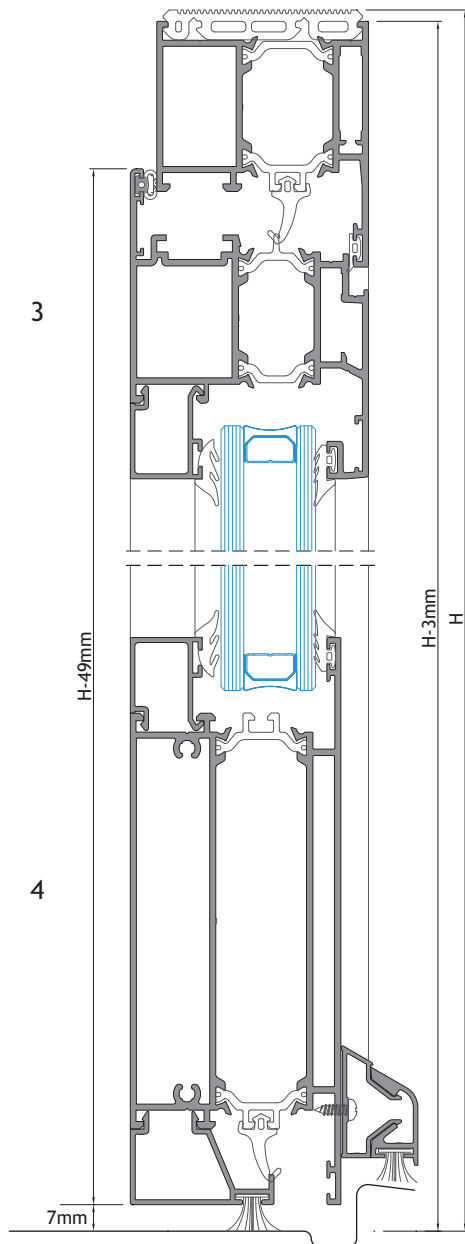
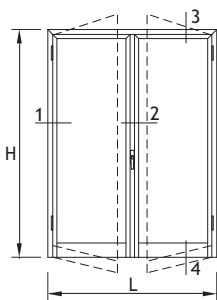

## PORTA DE 1 FOLHA - ABERTURA PARA EXTERIOR

1 LEAF DOOR - OUTWARD OPENING

PORTE 1 VANTAIL - OUVERTURE VERS L'EXTÉRIEUR

PERFIS PROFILES   PROFILS				
REFERÊNCIA REFERENCE RÉFÉRENCE	CORTE HORIZONTAL HORIZONTAL DETAIL DÉTAIL HORIZONTAL	CORTE VERTICAL VERTICAL DETAIL DÉTAIL VERTICALE	QUANTIDADE QUANTITY QUANTITÉ	CORTE CUT COUPÉ
IT-07	L-6	H-3	1+2	
IT-12	L-84	H-49	2+2	
IT-14	L-217	-	1	
AT-59	L-227	-	1	
SA-31	L-267	-	1	
SA-32	L-84	-	1	
-	L-227	H-290	2+2	

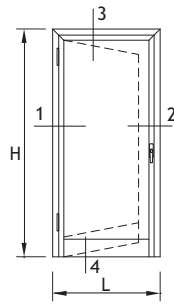

ACESSÓRIOS ACCESSORIES   ACCESSOIRES		
CÓDIGO CODE	DESIGNAÇÃO DESIGNATION   DÉSIGNATION	QUANTIDADE QUANTITY   QUANTITÉ
213246	CANTO CR S/SB   ANGLE   COIN	2
204139	ESQUADRO IT/ST Nº3 16-1931-C   BLOCKING BRACKET   ÉQUERRE	2
204730	ESQUADRO AT E. G.   BLOCKING BRACKET   ÉQUERRE	2
213247	CANTO CR 0182   ANGLE   COIN	4
202010	DOBRADIÇA MECANICA 1145/60   HINGE   PAUMELLE	2
223100	KIT FIXAÇÃO 1145.705   FIXATION KIT   KIT FIXATION	2
218170	CALÇO 1145.703/7   SHIM   CALE	2
201033	FECHADURA 7797x30   LOCKER   SERRURE	1
207403	SEGREDO 60/30   CYLINDER LOCK   CYLINDRE DE SERRURE	1
220008	ESPELHO P/SEGREDO 5100   CYLINDER BACK PLATE   COUVERCLE DE CYLINDRE	1
200747	PUXADOR DUPLO 874.3   HANDLE   POIGNÉE	1
227301	QUADRA AÇO 8X140   STEEL SQUARE SHAFT   BARRE SECTION CARRÉE	1
280220	TESTA FECHADURA PRUMO 2000   STRICKING PLATE   GÂCHE	1
212346	CONJUNTO TAPA-TOPOS SA32   END-CAP KIT   KIT DE EMBOUTE	1
218194	CALÇOS P/VIDRO EURO2000   GLAZING SHIM   CALE P/VITRAGE	4
225155	PASSADOR REVERSÍVEL 1550   2ND LEAF LOCKER   FERMETURE POUR 2ÈME VANTAIL	2
225154	HASTE-FECHO 1550.801   EXTENSION ROD   HAMPE D'EXTENSION	1
202077	CONTRA-FECHO 1404   COUNTER-LOCK   CONTRE-FERMETURE	1
211103	PONTO-FECHO PAVIMENTO 1409/8   FLOOR KEEPER   POINT DE CLÔTURE	1

VEDANTES SEALANTS   JOINTS		
CÓDIGO CODE	DESIGNAÇÃO DESIGNATION   DÉSIGNATION	QUANTIDADE QUANTITY   QUANTITÉ
208145	VD 2079	L+2H
208008	VD 2051 (1)	L+2H
208184	VD 2412 (opcional   optional   optionnel)	L+2H
208186	VD 2105 (2)	2L+2H
208350	VD 2003	2L+2H
VARIÁVEL VARIABLE	JUNTA INTERIOR   GLAZING WEDGE GASKET   JOINT INTÉRIEUR	2L+2H
213290	CANTO VULCANIZADO 2105.1   CORNER JOINT   JOINT VULCANISÉ	2
208464	PELÚCIA 8.5x12 STOP-FIN   PLUSH   JOINT BROUSSE	2L

- (1) 208143 VD 2071 (alternativa ao VD 2051 | alternative | alternative)  
 (2) 208144 VD 2305 (alternativa ao VD 2105 | alternative | alternative)

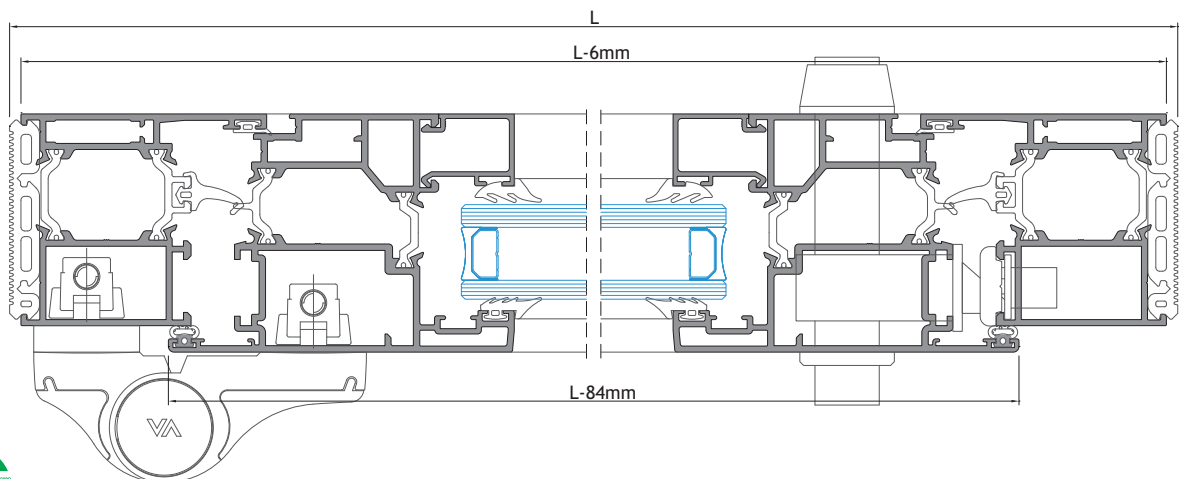
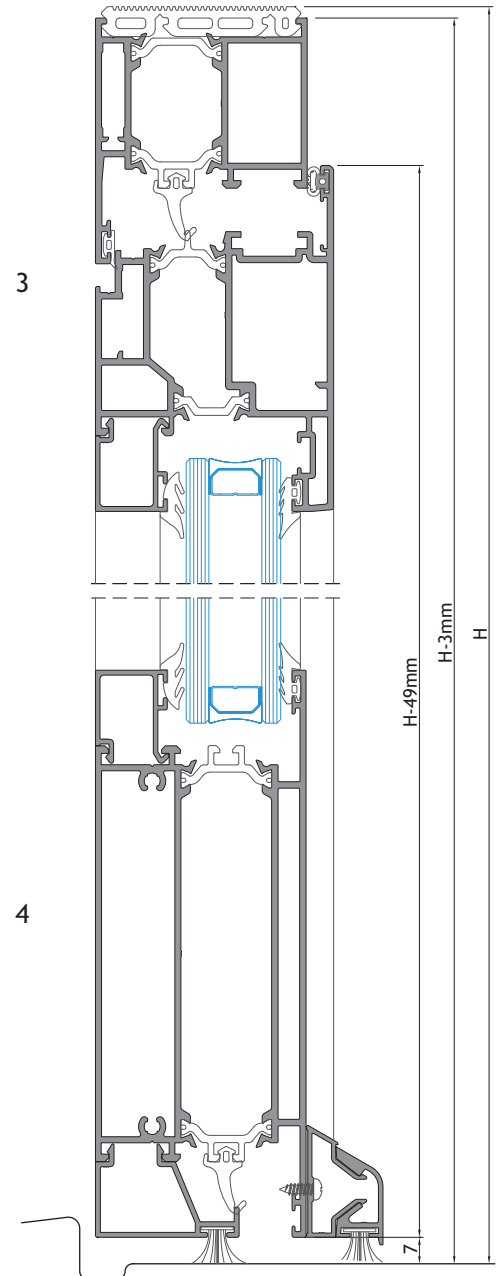

**LINHA RENOVATIO**

LINE RENOVATIO

LIGNE RENOVATIO

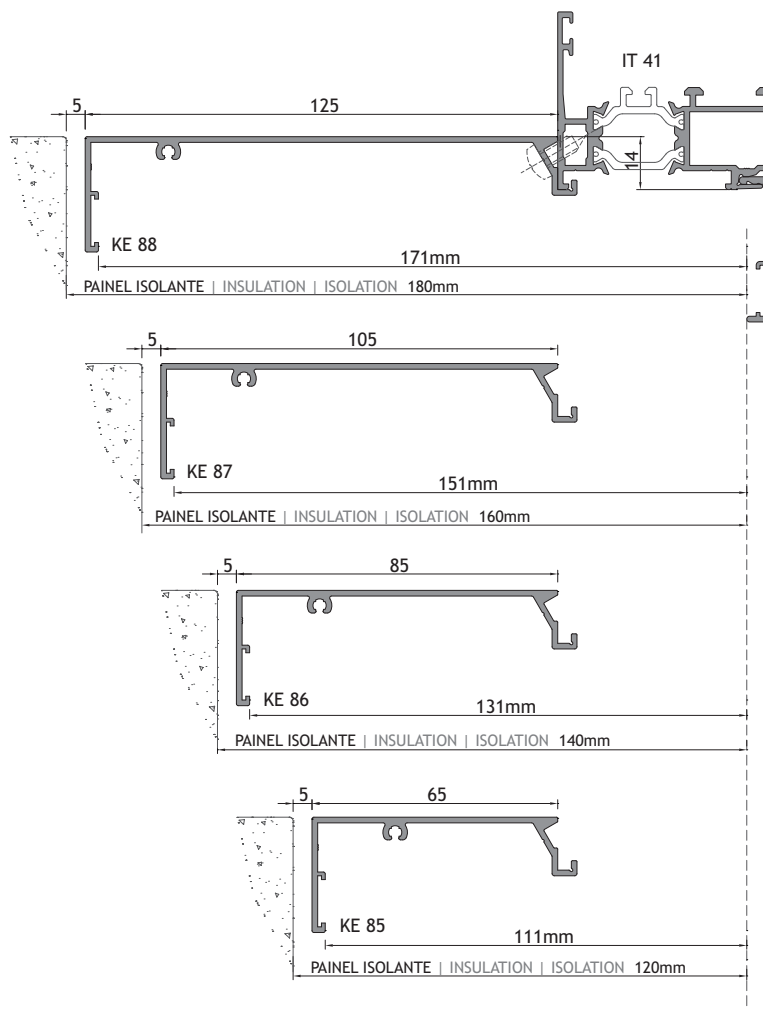
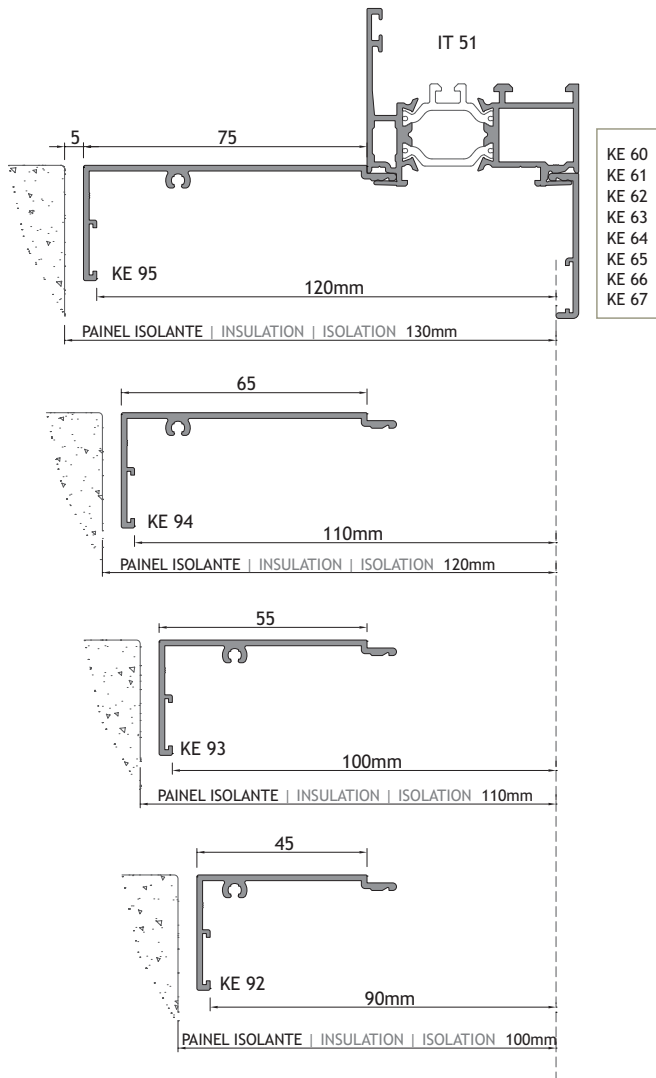









SISTEMAS  
**EURO 2000**®  
PERFIS DE ALUMÍNIO E VIDROS PARA ARQUITECTURA

## SOSOARES

Rua do Campo Alegre, 474  
4150-170 Porto  
T +351 226 096 709 | F +351 226 005 642  
E [comercial@sosoares.pt](mailto:comercial@sosoares.pt)

## METALFER

Travessa do Bolegão, 146  
Apartado 1  
3754-904 Fermentelos  
T +351 234 729 740 | F +351 234 729 741  
E [metalfer@sosoares.pt](mailto:metalfer@sosoares.pt)

## ALFA SUL

EN Lisboa-Sintra Km 14  
2725-397 Mem Martins  
T +351 219 265 090 | F +351 219 265 098  
E [alfa.sul@sosoares.pt](mailto:alfa.sul@sosoares.pt)

## ALULIDER

Pavilhão Industrial H - Plataforma 13D  
Zona Franca Industrial  
9200-047 Caniçal - Madeira  
T +351 291 960 494 | F +351 291 960 497  
E [alulider@sosoares.pt](mailto:alulider@sosoares.pt)

## PERFIS OEIRAS

Rua da Colónia - Quinta da Cardosa  
Apartado 214 - Abrunheira  
2711-952 Sintra  
T +351 219 156 660 | F +351 219 156 661  
E [perfis.oeiras@sosoares.pt](mailto:perfis.oeiras@sosoares.pt)

[www.sosoares.pt](http://www.sosoares.pt)

